

**AXICO Anti-stall®**

*Axial flow fan*



AIRTREND Ltd.  
Predstavništvo u Beogradu  
Kumanovska 14, 11000 Beograd  
Tel: 011/3836886, 3085740  
Faks: 011/3444113  
e-mail: [gobrid@eunet.rs](mailto:gobrid@eunet.rs)  
web: [www.airtrend.rs](http://www.airtrend.rs)

**FläktWoods**



**AXICO ANTI-STALL®**  
**FPAC and FPMC axial-flow fans**

For variable air flow by means of controllable pitch blades.

The fans have completely stable flow/pressure characteristics, which eliminates the risk of surging.

Air flow range: 3 - 110 m³/s (10 000 - 400 000 m³/h).

Pressure rise: Up to 3000 Pa.

Air temperature range: -15 to + 40°C with regard to the insulation class of the motor.  
 A quotation for a special version for other temperatures will be submitted on request.

- Good operating economy
- Surge-free operation
- Good control economy - the fan blades are instantly set to meet the flow requirements of the installation, without impairing the high efficiency
- Choice of suitable hub diameter and blade angle for optimum matching to the desired operating point
- Standard 4-pole or 6-pole foot-mounted motor or two-speed motor
- Low vibration level
- Low mass-moment of inertia - short starting time
- Short overall length
- Complete range of accessories
- Surface treated with 80-micron coat of alkyd paint

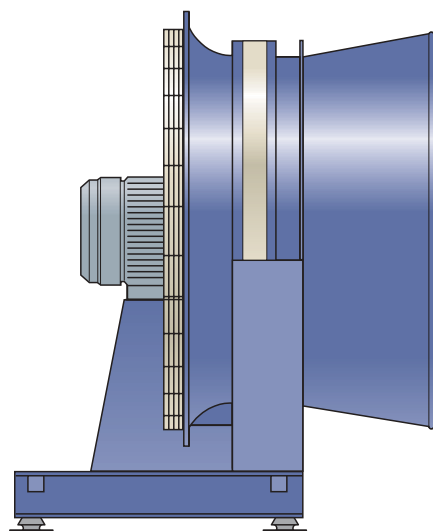

The FPAC-1 axial-flow fan with CD guide vane diffuser.

**Applications**

**Comfort ventilation**

Air handling units with **AXICO ANTI-STALL®** fans are used principally in hospitals, offices, hotels, exhibition halls, sports arenas, shopping centres and similar buildings. All efforts are being made to achieve maximum compactness of conventional modular air handling units, in order to minimize building costs and space requirements. The **AXICO ANTI-STALL® CD** range of fans has been developed specifically for such air handling units. CD stands for compact design. To make the fan as compact as possible, the guide vane section is integrated with a diffuser. The CD converts dynamic pressure into static without adding the length of a separate diffuser. Its short overall length makes the **AXICO ANTI-STALL® CD** fan eminently suitable for all air handling units.

**Process ventilation**

What we normally recognize as process ventilation is the type of ventilation used in industrial plants, power stations, mines, paint shops clean rooms, offshore installations, garages and so on. Common criteria of all these plants are the strict demands as to factors such as reliability, resistance to corrosive environments (temperature, humidity), stable operating characteristics, spark-proof design and control accuracy. **AXICO ANTI-STALL®** fans usually meet the industrial requirements and can be adapted to meet specific requirements regarding materials, surface treatment, spark-proof design, special motors, special designs, etc. For particulars of the special variants available, consult your nearest Fläkt Woods AB representative.

**Contents**

Design .....	4	Fan charts .....	11
General survey chart .....	5	Ordering key .....	21
Accessories .....	6	Acoustic data .....	22
Aspects of fan selection .....	7	Dimensions and weights .....	24
Sizing .....	8	Conversion factors, qualities and units, formulae .....	33
Control .....	10	Electric motors .....	34

## Design

The fan is supplied as a complete unit consisting of a casing with stabilizing ring, guide vane assembly, impeller, blade pitch control mechanism, guard, motor to IEC standard, and motor stand. Anti-vibration mountings of high damping rubber type and a flexible duct of PVC-coated nylon fabric for connection to an outlet duct are supplied.

In arrangement 6, the fan is also supplied with a flexible duct on the suction side.

The unique stabilizing ring controls and stabilizes the turbulence occurring in a heavily throttled fan. An axial fan without this stabilizing ring would be forced to surge, which may eventually lead to material fatigue and operation disturbances.

### The fan is available in two versions:

**FPAC** The blade angle is controlled by a diaphragm motor located in the hub of the impeller. The diaphragm motor is pneumatically actuated by means of a positioner. The FPAC offers accurate control of the blade angle, combined with fast response. The positioner operates with a pneumatic input signal or with an electric input signal as an option.

**FPMC** The blade angle is controlled by an electromechanic actuator operating on a control lever. The actuator is an accessory which, when ordered simultaneously with the fan, is fitted to the outside of the casing.

## Materials and finish

The main components of the impeller (hub, blades, etc.) are made of cast aluminium alloy. The control disc is made of cast iron. Other components of the fan, such as casing, stand, fasteners, shafts, etc., are mainly made of steel.

The fan is painted with an 80-micron thick coat of blue alkyd paint. The fasteners are galvanized.

### Environmental class C1, ISO 9223

Fans to higher environmental class up to and including C4 are available to special order.

### Installation

The fan is to be mounted on the supplied anti-vibration mountings which are secured to the floor. Instructions are submitted with the fan.

### Packaging

The fan is delivered on a pallet, and is protected with plastic sheeting.

## Arrangements available

### Arrangement 1

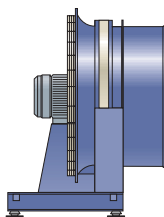

The fan impeller is mounted directly on the motor shaft. This is a compact arrangement which is particularly suitable for air handling units.

### Arrangement 3

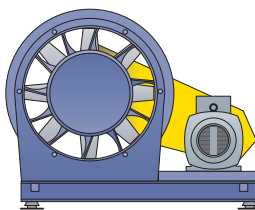

The impeller is belt-driven for high total pressure capacity. For particulars of speeds, see the motor table on page 20. The motor is slidably mounted on a base frame, which makes the belt tension easy to adjust. The belt drive is provided with a galvanized steel guard.

### Arrangement 6

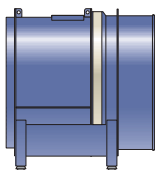

Horizontal

The impeller is mounted directly on the motor shaft. This arrangement is intended for connection to ducting on both sides. The FPAZ-21 inlet is used for open-suction installation. The fan can also be installed vertically.

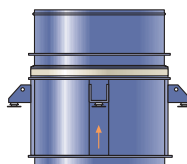

Vertical, with upward direction of air flow

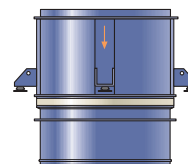

Vertical, with downward direction of air flow

### Arrangement 7

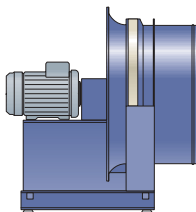

The impeller is mounted on an intermediate shaft connected to the motor by means of a highly elastic flexible coupling. The intermediate shaft is journaled in two bearing blocks. Grease nipples for periodic lubrication of the bearings are provided on the outside of the fan and are easily accessible. The motor can easily be replaced without the impeller and control components being disturbed.

**General survey chart**

The chart is applicable to gas with a density of 1.2 kg/m<sup>3</sup>

**Detailed charts**

Size 080 .....	pages 11, 12	Size 125 .....	pages 16, 17
Size 090 .....	pages 12, 13	Size 140 .....	pages 17, 18
Size 100 .....	pages 13, 14	Size 160 .....	pages 18, 19
Size 112 .....	pages 14, 16	Size 180 .....	pages 19, 20

**Arrangement 1, 6 and 7**

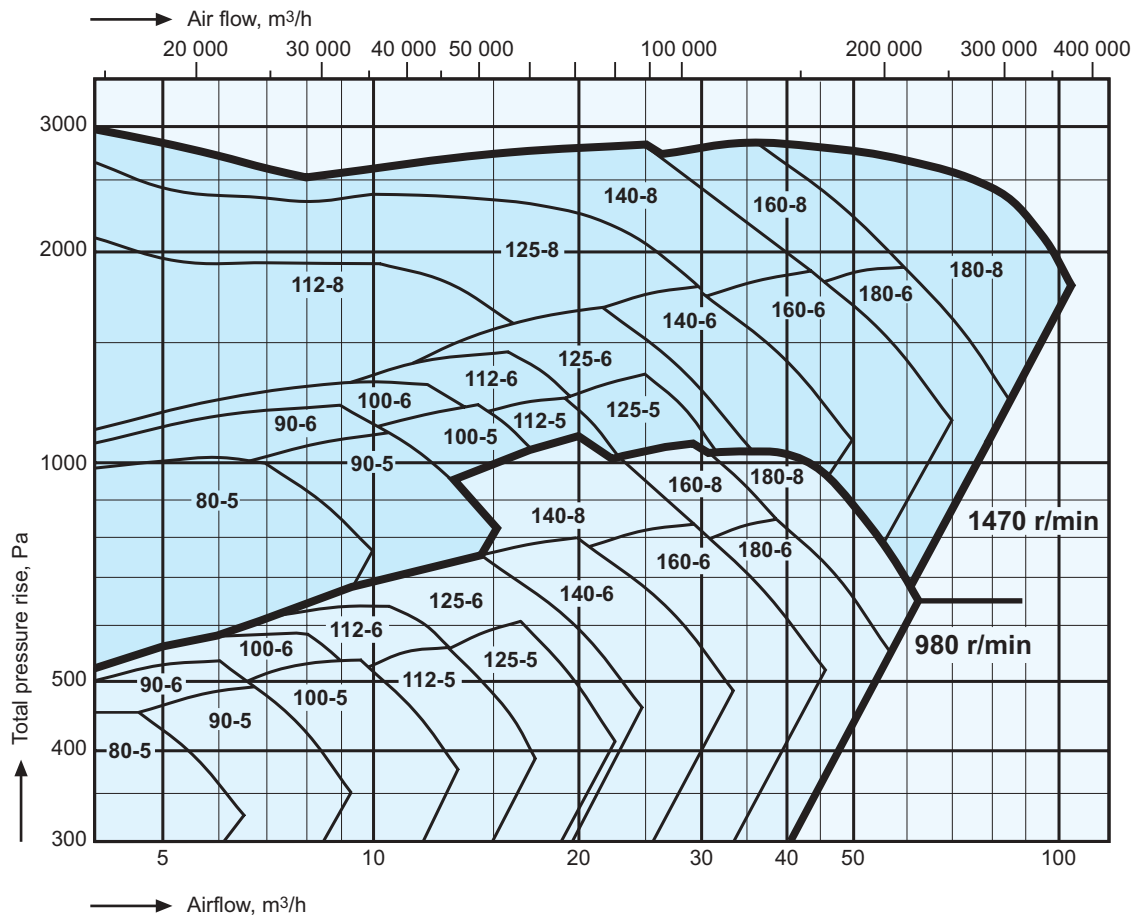

**Arrangement 3**

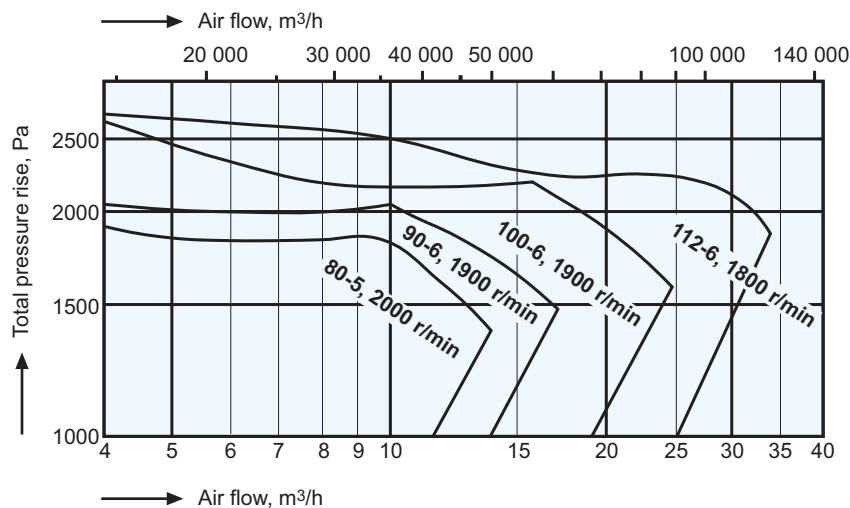

The adjacent charts refers to the max.speed of belt-driven fans. Detailed charts appear on pages 11 - 20.

For determining the most suitable fan speed, contact your nearest Fläkt Woods AB sales office.

## Accessories (to be specified separately)

### AXICO ANTI-STALL® CD (compact design)

**FPAZ-01, FPMZ-01 guide vane diffusers of CD design**, mounted on the fan instead of the cylindrical guide vane unit. This minimises the overall length of the fan/diffuser installation, at the same time reducing the air velocity. The guide vane diffuser is made of sheet steel and is provided with the same surface treatment as the fan.

The **CD version** is particularly suitable wherever a short overall length is important, such as in an air handling unit.

**FPAZ-02 diffuser** is particularly suitable wherever a short overall length is important, such as in an air handling unit.

**FPAZ-03 long diffuser** of galvanized sheet steel for connection to the fan outlet by means of a flexible duct. The diffuser reduces the air velocity to a suitable level for connection to the ducting or to a plenum chamber. The FPAZ-03 converts the dynamic pressure to static pressure at high efficiency, so that a maximum of the pressure generated by the fan will be utilized.

Note. *The FPAZ-02 together with the FP(A,M)Z-01 CD diffusers provides a dynamic pressure recovery equal to that of the FPAZ-03, but within a shorter overall length.*

**FPAZ-04 air distributor** for connection directly downstream of the AXICO fan. The FPAZ-04 distributes the air with a uniform velocity profile over a large area. The distributor has a very short overall length and low pressure loss. The connection loss is shown in the chart, Fig. 1 on page 9. Due to the low pressure loss, the air distributor is particularly suitable as a transition piece for connection to a heating coil or baffle-type silencer.

**FPAZ-05 air distributor** for connection downstream of the FPAZ-01 or FPMZ-01 guide vane diffuser or FPAZ-02, -03, or -25 diffuser. Features, see FPAZ-04.

Note. *The FPAZ-06 transition piece must be ordered for connecting the air distributor to the FP(A,M)Z-01 guide vane diffuser.*

**FPAZ-06 transition piece** for connecting the FPAZ-05 air distributor directly to an FP(A,M)Z-01 guide vane diffuser. The transition piece is made of sheet steel and is provided with the same surface treatment as the fan.

**FPAZ-21 inlet with protective grille** is intended for arrangement 6 and free inlet installation.  $\Delta p = 0.15 \times p_d$ .

**FPAZ-24 silencer** is designed for horizontal or vertical installation. The entire silencer is made of galvanized sheet steel. The internal sheet-steel liners including that of the central core are perforated and are provided with sound-absorbing mineral wool behind the perforations. The silencer is to be connected to the ducting by means of a flexible duct.

Flexible ducts should be used for connection to the fan, and an appropriate number of flexible ducts is delivered with the fan.

An arrangement 6 fan can be installed with silencers on both sides. For particulars of the pressure drop across the silencer, the total sound attenuation in dB(A) and the division into different octave bands, see page 31.

Silencers can be sized and supplied to suit special applications. For further particulars, consult your nearest Fläkt Woods representative.

**FPAZ-25 acoustic diffuser** provides sound attenuation and is designed for connection to a flexible duct. The diffuser reduces the air velocity to a suitable level for connection to ducting or to a plenum chamber. The dynamic pressure is converted at high efficiency to static pressure, so that a maximum of the pressure generated by the fan will be utilised. The outer casing of the diffuser is made of painted sheet steel, while the inner casing and centre element are made of galvanized, perforated sheet steel. The diffuser casing and centre element incorporate sound-absorbing mineral wool. The design provides a high degree of sound attenuation, above all within the octave bands between 500 and 4000 Hz (see the table on page 32).

Note. *The galvanized sheet steel mentioned above is sheet steel which has been galvanized in accordance with the Sendzimir method. This process results in a coating of 275 g of zinc per m<sup>2</sup> of sheet, which provides a zinc coating of approx. 20 µm (microns) per side.*

**FPAZ-33 flexible duct** for flange-sleeve connection is used for adapting the FPAZ-24 sound absorber when a flanged connection is required.

**EBGA counterflange** for the outlet diffuser. The dimensions are in accordance with ISO 6580 and EUROVENT 1/2 (see page 32).

**EBGV grouting-in-frame** for the outlet diffuser. The dimensions are in accordance with ISO 6580 and EUROVENT 1/2. (see page 32).

**FPMZ-07, FPMZ-09 and FPMZ-13 actuators** are designed for electric control of the blade angle (see page 28).

**FPAZ-14 electro-pneumatic positioner** to be used when a 4-20 mA signal is specified to control an FPAC fan. The positioner can be used together with FPAZ-16 pressure control equipment, for instance.

**FP(A,M)Z-16 control equipment** is a complete system for automatic control of one or two AXICO fans. The system provides a constant pressure at the measuring point. The system can be used for supply air fans as well as for exhaust air fans.

The **FPAZ-16** system is intended for the FPAC fan with pneumatic control, which has been equipped with the FPAZ-14 electro-pneumatic positioner. The FPAZ-16 is also well suited for use with actuators having continuous input signal: FPMZ-07-2, FPMZ-09-2 or FPMZ-13-2, for instance. It consists basically of a controller with built-in pressure sensor.

The FPAZ-16 is enclosed in a cabinet on delivery. Fitting components for distances up to 25 m between the controller and the measurement point are supplied.

### Technical particulars, setting range:

FPAZ-16 -05	0 - 500 Pa
-10	50 - 1000 Pa
-20	100 - 2000 Pa

Connection: 8 mm o.d./6mm i.d. plastic hose for compressed air.

Power supply: 220 V, 50 Hz, 5 A fuse

Cabinet: 380 mm wide x 300 mm high x 155 mm deep.

Degree of protection: IP 66

The FPMZ-16 is intended for the FPMC fan which has been equipped with a pulse-type, electro-mechanical actuator, FPMZ-07-1, FPMZ-09-1 or FPMZ-13-1, for instance. It consists basically of a controller with built-in pressure sensor.

The FPMZ-16 is enclosed in a cabinet on delivery.

Fitting components for distances up to 25 m between the controller and the measurement point are supplied.

### Technical particulars, setting range:

FPMZ-16 -05	0 - 500 Pa
-10	50 - 1000 Pa
-20	100 - 2000 Pa

Power supply: 230 V, 50/60 Hz, 5 A fuse

Cabinet: 380 mm wide x 300 mm high x 155 mm deep.

Degree of protection: IP 66

The **FPAZ-70** is a complete system for automatic air flow control of free inlet, type FPAC-1 and FPAC-7 AXICO fans.

The system can be easily adapted to control several fans operating in parallel.

The FPAZ-70 has an input for external set point value and a flow-linear actual value output.

Current air flow readings in m<sup>3</sup>/s or differential pressure readings are shown on a display, via a selector switch.

The equipment utilises air flow measurements in the fan inlet as actual values and must therefore be used in combination with the FPAZ-18. The flow is indicated as a static differential pressure between the fan inlet and the fan room. This is contingent on the fan size and should be known when ordering.

The following measurement ranges exist:

FPAZ-70 -05	0 - 500 Pa
-10	50 - 1000 Pa
-20	100 - 2000 Pa

Power supply: 230 V single-phase, 50/60 Hz, 5 A fuse  
 Dimensions: 380 mm wide x 300 mm high x 155 mm deep.  
 Degree of protection: IP 66

**FPAZ-17 flow measurement transmitter**

The transmitter measures the flow in the fan inlet and must therefore be used in combination with the FPAZ-18.  
 Current air flow readings in m³/s or differential pressure readings are shown on a display, via a selector switch. The flow is indicated as a static differential pressure between the fan inlet and the fan room.  
 The differential pressure is contingent on the fan size and should be known when ordering.

The following measurement ranges exist:

FPAZ-17 -05	0 - 500 Pa
-10	50 - 1000 Pa
-20	100 - 2000 Pa

The 4 - 20 mA output signal is proportional to the flow.  
 Power supply: 220 V single-phase, 50 Hz, 5 A fuse  
 Cabinet: 200 mm wide x 300 mm high x 155 mm deep.  
 Degree of protection: IP 55

**FPAZ-18 flow measurement tapping** for pressure measurement at the inlet of a free inlet fan, for measuring the static pressure differential between the inlet and the surroundings (fan room). Using the FPAZ-17 converter, this can be presented as a flow in m³/s.

**FPAZ-19 blade angle indicator** provides continuous indication of the actual blade angle of an FPAC fan and is factory-mounted near the positioner.

**FPMZ-19 blade angle indicator** provides continuous indication of the actual blade angle of an FPMC fan and is factory-mounted near the control lever.

Fig. 1 shows the connection loss  $\Delta p$  for all sizes of the FPAZ-04 air distributor connected directly to the fan. The total pressure rise  $\Delta p_t$  across the fan is obtained by adding  $\Delta p$  to the static pressure drop  $\Delta p_s$  across the installation.

$\Delta p_t = \Delta p_s + \Delta p$   
 $p_d = \text{dynamic pressure} \approx 0$

Example:  
 For a size 125 - 6 fan and a flow rate of 20 m³/s, the pressure loss will be 150 Pa.

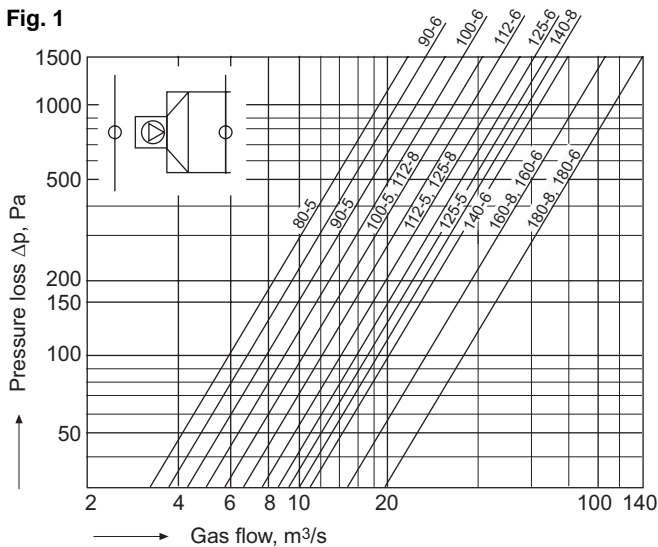
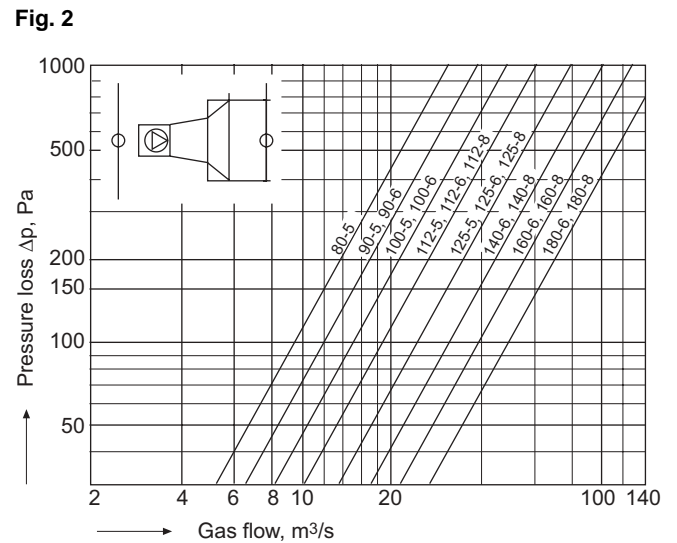

Fig. 2 shows the connection loss  $\Delta p$  of the FPAZ-03<sup>1)</sup> diffuser combined with the FPAZ-05 air distributor. The total pressure rise  $\Delta p_t$  of the fan is obtained by adding  $\Delta p$  to the static pressure drop  $\Delta p_s$  across the installation.

$\Delta p_t = \Delta p_s + \Delta p$   
 $p_d = \text{dynamic pressure} \approx 0$

Example:  
 For a size 125 - 6 fan and a flow rate of 20 m³/s, the total loss across the diffuser and air distributor will be 66 Pa.



<sup>1)</sup> The connection loss of the FPAZ-05 air distributor in combination with the FPAZ-01 or FPMZ-01 diffuser, of CD design, is shown as  $\Delta p_2$  in each fan chart.

**Aspects of fan selection**

AXICO fans are characterized by high efficiency over a wide operating range. The design load should be selected far to the right in the charts. This can be done if the connection loss is restricted, such as by using a diffuser and air distributor. The normal operating points at partial loads will then also be located in the high-efficiency zone. The curves in the AXICO ANTI-STALL<sup>®</sup> pressure/flow charts are perfectly stable. The risk of surging (i.e. instability of the fan pressure and consequent pressure fluctuations) encountered on conventional vane axial fans is thus completely eliminated. The performance of the AXICO fan will therefore be maintained stable even in the event of the system resistance increasing more than expected. The maximum blade angle specified in the fan charts is the maximum angle for which the fan is designed.

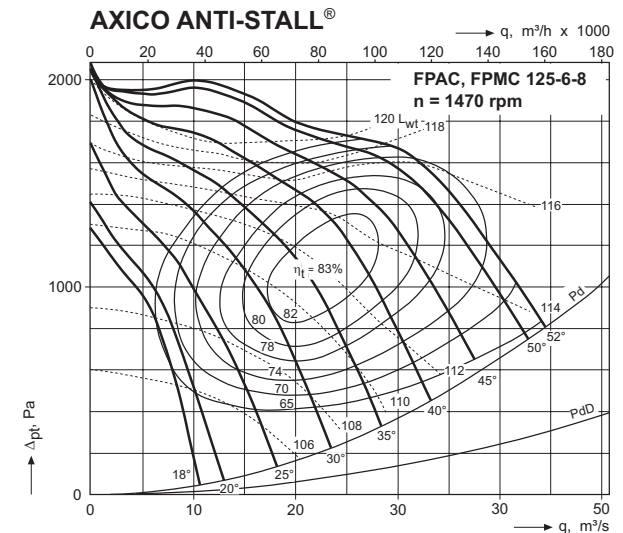

## Sizing

The charts are applicable to air with a density of 1.2 kg/m<sup>3</sup>. The pressure/flow characteristic of the fan is presented as a total pressure rise  $\Delta p_t$  between the fan inlet and the fan outlet, provided that the fan is connected to ducting having the same diameter as that of the fan. The charts are applicable to both free inlet fans and fans connected to ducting, and do not include any belt drive loss. The capacities and acoustic data in the charts are based on measurements in accordance with the AMCA 210-85 and AMCA 300-85 (Air Movement and Control Association Inc.) methods respectively. The connection of the fan may vary, depending on the design of the ventilation system and the requirements. The outlet side of the fan is often connected across a diffuser to a plenum chamber or a duct. Combinations of CD diffuser, air distributor and silencer offer benefits in terms of space required, low sound level, overall economy, etc. The connection losses for connection cases other than that of connection directly to the ducting can be read on the scales at the right-hand bottom.

The connection case may be one of the following five:

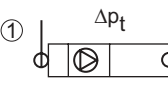
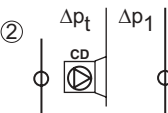
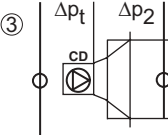
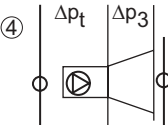
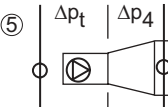
- ①  Fan connected directly to a duct.  
The connection loss is included in the chart.  
 $\Delta p_t = \Delta p_s + p_d$
- ②  CD fan with an FP(A,M)Z-01 guide vane diffuser connected to a plenum chamber.  
 $\Delta p_t = \Delta p_s + \Delta p_1$
- ③  CD fan with an FP(A,M)Z-01 guide vane diffuser and FPAZ-05 air distributor connected to a duct.  
 $\Delta p_t = \Delta p_s + \Delta p_2$
- ④  Fan connected to a plenum chamber across a FPAZ diffuser.  
 $\Delta p_t = \Delta p_s + \Delta p_3$
- ⑤  Fan connected to a duct across a FPAZ diffuser.  
 $\Delta p_t = \Delta p_s + \Delta p_4 + p_{dD}$

- $\Delta p_t$  = total pressure rise across the fan (from chart)
- $\Delta p_s$  = static pressure rise across the installation
- $\Delta p_1, \Delta p_2, \Delta p_3, \Delta p_4$  = connection loss
- $p_d$  = dynamic pressure in the connected duct
- $p_{dD}$  = dynamic pressure in the connected duct after diffuser

Connection cases ① and ⑤ presuppose that the straight section of duct, downstream of the fan or diffuser, has a length of at least 2.5 times the nominal diameter of the fan or diffuser. The connection loss in an installation with a type FPAZ-04 or FPAZ-05 air distributor can be read from the chart on page 7.

Two curves showing the dynamic pressure are plotted in the fan charts:

- $p_d$ : In a duct with an area corresponding to the nominal diameter of the fan, e.g. 1250 mm diameter for a size 125 fan. This corresponds to connection case ①.
- $p_{dD}$ : In a duct with an area corresponding to the outlet diameter of the FPAZ-03 diffuser. This corresponds to connection case ⑤.

The fan charts apply to fans with free inlet as well as to ducted inlet. For arrangement 1 and arrangement 6 fans with FPAZ-21 inlet, add a loss of  $0.15 \times p_d$  for the protective grille. See also page 11.

## Example of fan selection

### Given:

A fan operating under variable flow and pressure conditions with the outlet connected to a duct across a diffuser (connection case ⑤).

Max. air flow: 30 m<sup>3</sup>/s. Normal load: 20-25 m<sup>3</sup>/s. Static pressure rise from fan inlet to duct: 1200 and 700-850 Pa respectively. Air density: 1.2 kg/m<sup>3</sup>.

If compressed air is available for the control, select the FPAC fan. Otherwise, select the FPMC with an electric actuator. See page 28 for the control force and selection of actuator.

### Solution:

Assume 150 Pa for the dynamic pressure and connection loss, which is added to the required static pressure. From the general survey chart on page 5, a size 125-6 fan with a 4-pole motor is selected. The following particulars can be obtained from the fan chart for this size.

Operating conditions	Flow m <sup>3</sup> /s		
	30	25	20
1) Density ..... kg/m <sup>3</sup>	1.2	1.2	1.2
2) Static pressure rise ..... Pa	1200	850	700
3) Speed ..... rpm	1470	1470	1470
4) Dynamic pressure in the duct ..... Pa	130	90	60
5) Connection loss ..... Pa	58	40	25
6) Total pressure rise across the fan ..... Pa	1388	980	785
7) Blade angle ..... degrees	47	37	31
8) Efficiency ..... %	81	82	81
9) Power demand ..... kW	51.4	29.9	19.4
10) Suitable motor rating ..... kW	55		
11) Max. blade angle ..... degrees	48		
12) Total sound power level ..... dB(A)	115	112	109
13) Annual operating time ..... h	250	2000	2000

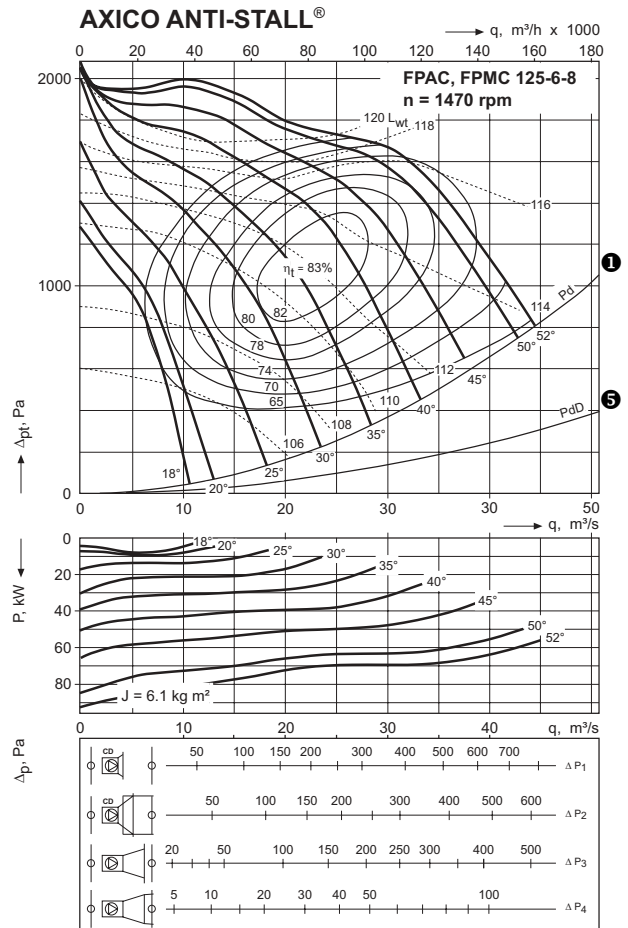



**Sizing (contd.)**

Annual operating cost:  
 $(51.4 \times 250 \text{ h} + 29.9 \times 2000 \text{ h} + 19.4 \times 2000 \text{ h}) \times \text{cost per kWh.}$

Items 1 - 13 in the above table are derived as follows:

- 1, 2) Given
- 3) From the general survey chart (page 5).
- 4) Read from the chart curves for dynamic pressure.  
The lower curve applies in this example, p<sub>dD</sub>, since a diffuser is included.
- 5) Read from the fan chart scales for the connection loss Δp<sub>4</sub>.
- 6) The required static pressure rise, the dynamic pressure plus connection loss read from the chart.
- 7, 8) Read from the chart - at the intersection of the given flow and the total pressure rise across the fan.
- 9) Read from the power chart - at the intersection of the given flow and the blade angle. Power is more accurately determined from the expression.

Power demand, kW =

$$\frac{\text{Flow, m}^3 \times \text{Total pressure rise across the fan, Pa}}{10 \times \text{Efficiency, \%}}$$

- 10) The maximum power demand from 9) above is 51.4 kW. Select a 55 kW motor which gives little margin for any increase in flow and rise in system resistance in relation to the calculated value. The next larger size of motor may be advisable.
- 11) When delivered from the factory, the AXICO ANTI-STALL® is fitted with mechanical stops which limit the blade angle to prevent overloading of the motor. Since the operating conditions vary from system to system in terms of temperature, density and system characteristics, the maximum blade angle required should be specified in the order. In the absence of this information, the maximum blade angle will be set to suit the motor rating. For an operating point along the same throttling curve, the maximum blade angle is 48°, since the motor rating is limited to 55 kW.
- 12) Read from the chart - at the intersection of the given flow and the total pressure rise across the fan.
- 13) To be specified by the customer.

**Example of connection cases**

As a means of demonstrating the differences in total pressure and power demand contingent on the connection case selected for a given system, a comparison between connection cases 1, 2, 3, 4 and 5 is presented in the table below.

The connection losses have been obtained from the appropriate scale and the dynamic pressure from the appropriate curve in the fan chart.

Note that different total pressures may give varying fan efficiencies, which will affect the overall economy.

Connection case	1	2	3	4	5
Flow ..... m <sup>3</sup> /s	25	25	25	25	25
Static pressure rise ..... Pa	850	850	850	850	850
Dynamic pressure ..... Pa	250	-	-	-	90
Connection loss ..... Pa	-	250	190	165	40
Total pressure rise across the fan ..... Pa	1100	1100	1040	1015	980
Fan output ..... kW	33	33	32	31	30

**Control**

The AXICO ANTI-STALL® is easily controlled so that it delivers the required flow in all situations. Suitable controllers include pulse controllers with variable pulse duration and neutral zone, or PI controllers with a P band of 80% or more. The sensor (transmitter) should be selected so that the controlled variable is approx. 70-90% of the maximum limit of the sensor.

The AXICO ANTI-STALL® can be adapted to the control signals that are standard in computerised control systems.

**FPAC fans**

**N.B. The fan includes a diaphragm motor and positioner (see below). Although other (external) control equipment is not included, it is available as the FPAZ-16 accessory.**

The blade pitch of the FPAC fan can be varied while the fan is running. This is done by means of a built-in diaphragm motor which is actuated by compressed air through a rotary coupling.

When the pressure at the diaphragm motor is atmospheric, the blades are in the minimum position, i.e. the fan delivers minimum air flow.

As the pressure at the diaphragm motor increases, the blade angle will change and the air flow through the fan will increase.

The position of the diaphragm motor is controlled by a linear positioner which eliminates hysteresis in controlling the blades, and the blade angles will therefore change linearly with the input control signal.

The positioner is available in two versions: either with a 20-100 Pa pneumatic control signal or with a 0-20/4-20mA electric control signal. The latter is optional, see accessory FPAZ-14 (and FPAZ-16).

In addition, the positioner has one input for the air supply to the diaphragm motor. The air should basically be free from oil, water and other impurities, i.e. it should be of instrument quality (air that contains no particles larger than 10 μm (microns) and has a dew point of -20°C or below.

For particulars of pressures, see page 28. Pressures above 550 kPa (5.5 atg.) should be avoided.

The air demand varies with the number of changes in position and the magnitudes of the changes. On average, about 0.3 l/s of air at s.t.p. is required. At an operating pressure of 400 kPa, 0.18 l/s of air is required when the positioner is at rest, and about 1.5 l/s of air is needed for the maximum stroke.

**FPMC fans**

The blades of FPMC fans are turned by linkage system actuated by an external motor. For particulars of control forces and actuators, see the table on page 28. The actuator must be ordered separately and is available as an accessory.

External control equipment, see accessory FPMZ-16.

**Examples of control equipment, see page 10.**

## Examples of control equipment

### Operation with one fan

The most common and simplest way of controlling the fan of a supply air system with varying flow requirements is to maintain a constant pressure in a plenum chamber or in the supply air duct. For the FPAC, e.g. FPAZ-16-bb, see Fig. 1.

For the FPMC, e.g. FPMZ-16-bb, see Fig. 2.

Exhaust air fans are controlled in the same manner, but with the pressure sensor located in a suction chamber (i.e. the fan room) or in exhaust air duct.

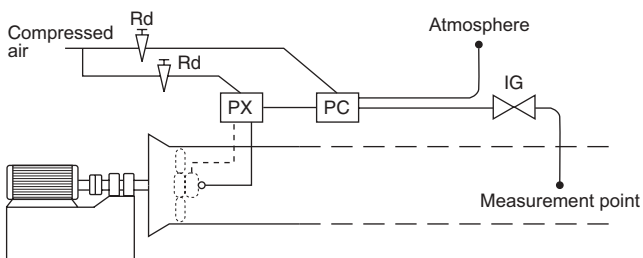

Fig. 1

- PC = Pressure controller (with built-in pressure sensor)
- PX = Pneumatic positioner or electro-pneumatic positioner (see page 9)
- IG = Integration vessel
- Rd = Reducing stations

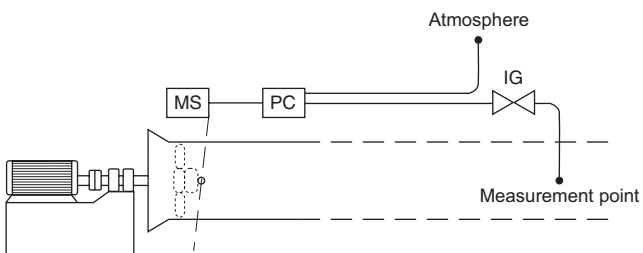

Fig. 2

- PC = Electronic pressure controller (with built-in pressure sensor)
- MS = Electro-mechanic actuator
- IG = Integration vessel

### Parallel operation of the FPAC

This is done by the signal from converter PC (Fig. 1) being branched off to the positioners PX of two or more fans.

### Parallel operation of the FPMC

Two fans can be controlled in parallel by the second fan being on follower control via a servo controller. The actuators of both fans must be equipped with potentiometers (see Fig. 3).

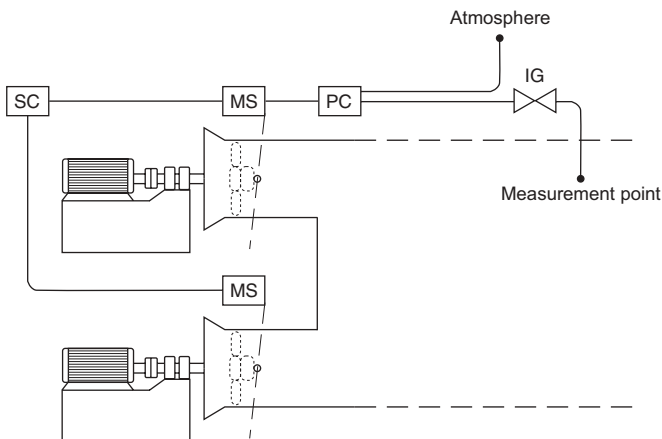

Fig. 3

- PC = Electronic pressure controller (with built-in pressure sensor)
- SC = Electronic servo controller
- MS = Electric actuator
- IG = Integration vessel

## Supply and exhaust air system

It may sometimes be beneficial to control a supply air fan and an exhaust air fan so that the air flows delivered by the two fans follow one another.

The supply air fan is controlled in the conventional manner, so that the pressure in the plenum chamber or duct is maintained constant. By measuring the flow through each fan, the exhaust air fan can be controlled to follow the supply air fan exactly or with a predetermined flow differential (see Fig. 4)

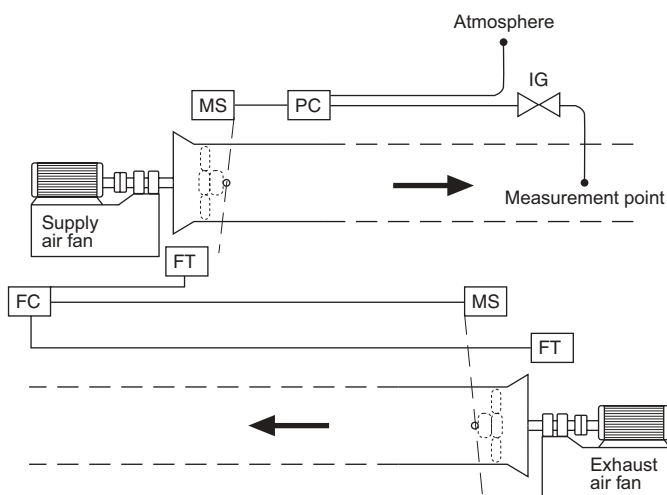

Fig. 4

- PC = Electronic pressure controller
- MS/PX = Electro-mechanic actuator/electro-pneumatic positioner
- FC = Electronic flow controller
- FT = FPAZ-17 Linear electronic pressure transmitter in combination with FPAZ-18
- IG = Integration vessel

## Supply and exhaust air systems with parallel fans

Two parallel fans for supply air and two parallel fans for exhaust air (a total of 4 fans) should be controlled by two separate control systems.

## Fan charts

The charts are applicable to gas with a density of 1.2 kg/m<sup>3</sup> and do not include belt drive loss.

- Arr. 3 and 7 Apply including protective grille
- Arr. 1 A connection loss of 0.15 × p<sub>d</sub> must always be added for the protective grille.
- Arr. 6 On free inlet fans with FPAZ-21 protective grille, a connection loss of 0.15 × p<sub>d</sub> must be added

### Symbols used

- ① = fan size and speed
- ② q, m<sup>3</sup>/s (h) = air flow
- ③ Δp<sub>t</sub>, Pa = total pressure rise, from the inlet to the entire outlet area
- ④ P, kW = power demand
- ⑤ degrees = blade root setting angle
- ⑥ η<sub>t</sub>, % = maximum overall efficiency of the fan
- ⑦ η, % = overall efficiency of the fan
- ⑧ L<sub>wt</sub>, dB(A) = total sound power level
- ⑨ P<sub>d</sub>, Pa = dynamic pressure in the duct with the same diameter as the fan outlet
- ⑩ P<sub>dD</sub>, Pa = dynamic pressure in the duct with the same diameter as the outlet of the FPAZ-02, -03 and -25 diffuser
- ⑪ Δp<sub>1</sub>, Pa = connection loss for a fan of CD-design with FP(A,M)Z-01 guide vane diffuser connected to a large chamber
- ⑫ Δp<sub>2</sub>, Pa = connection loss for a fan with FP(A,M)Z-01 guide vane diffuser and FPAZ-05 air distributor fitted to a duct
- ⑬ Δp<sub>3</sub>, Pa = connection loss for a fan with diffuser fitted to a large chamber
- ⑭ Δp<sub>4</sub>, Pa = connection loss for fan with diffuser fitted to a duct
- ⑮ J, kg m<sup>2</sup> = mass moment of inertia (=1/4 GD<sup>2</sup>)

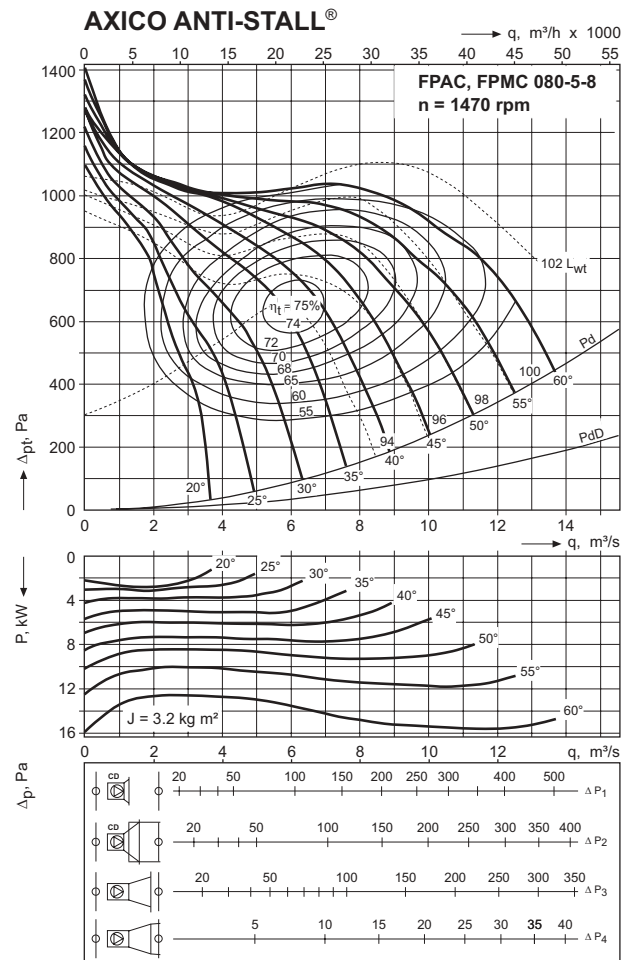
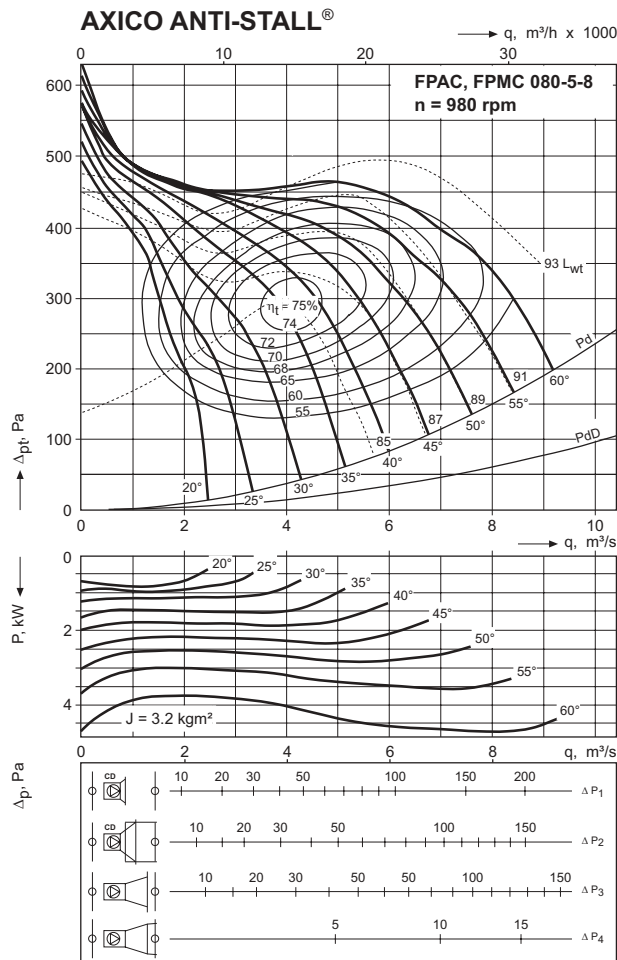
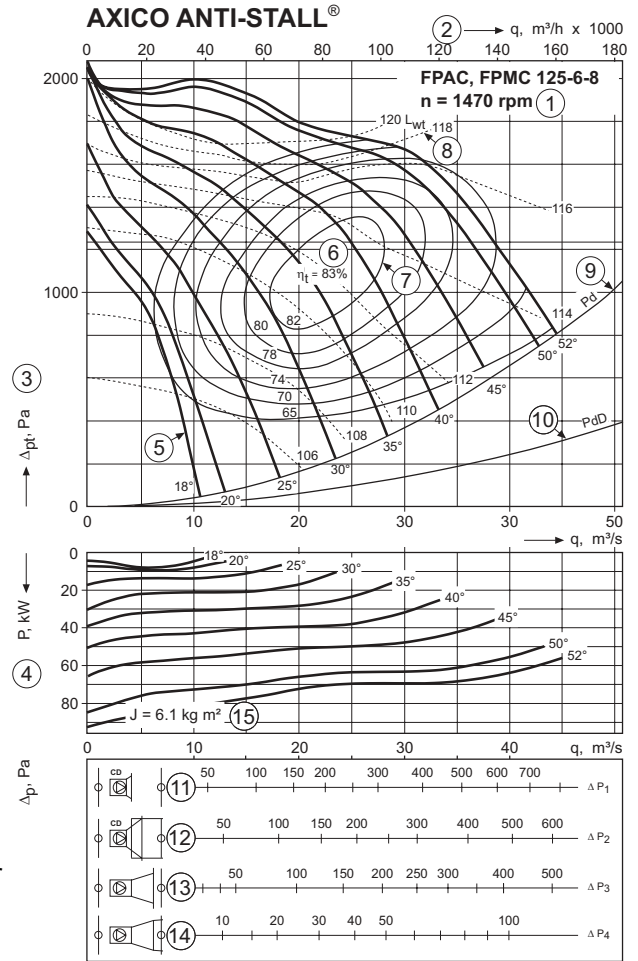

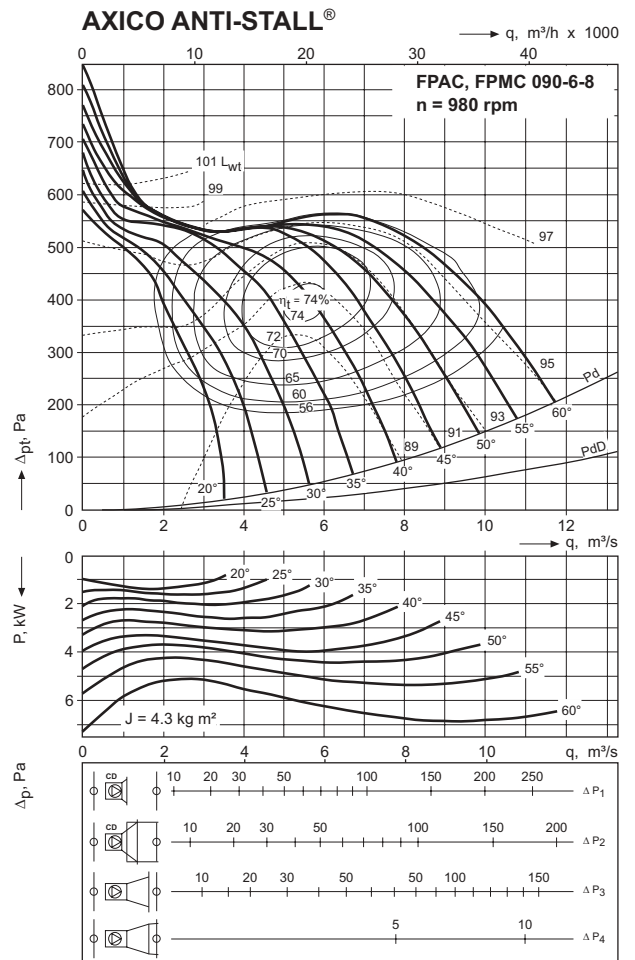
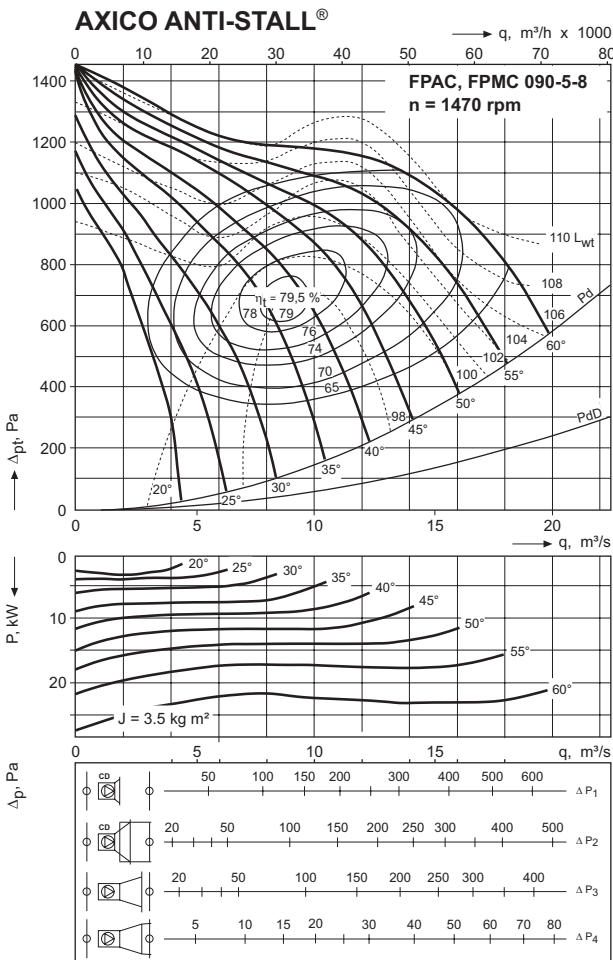
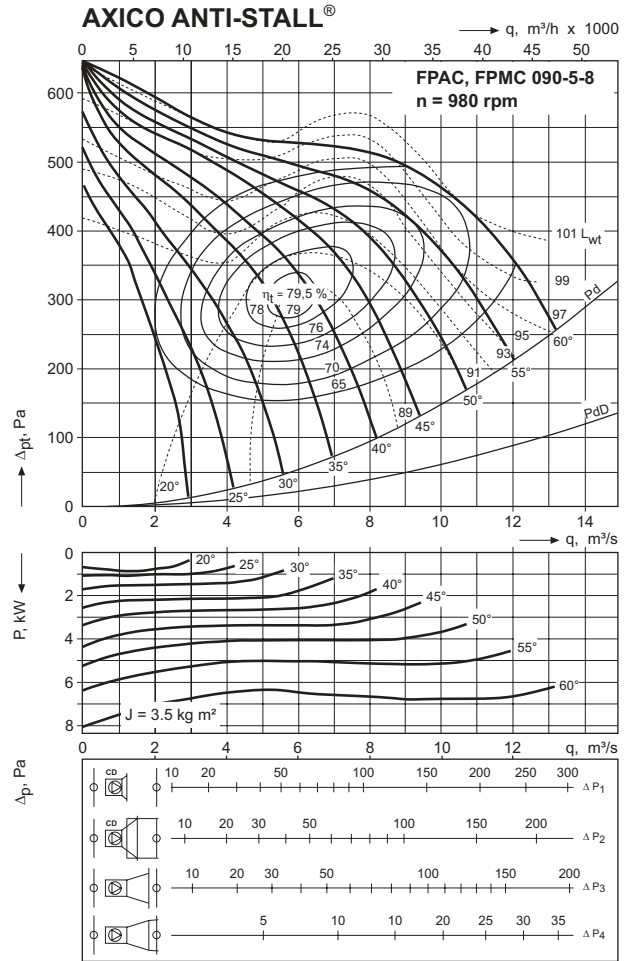
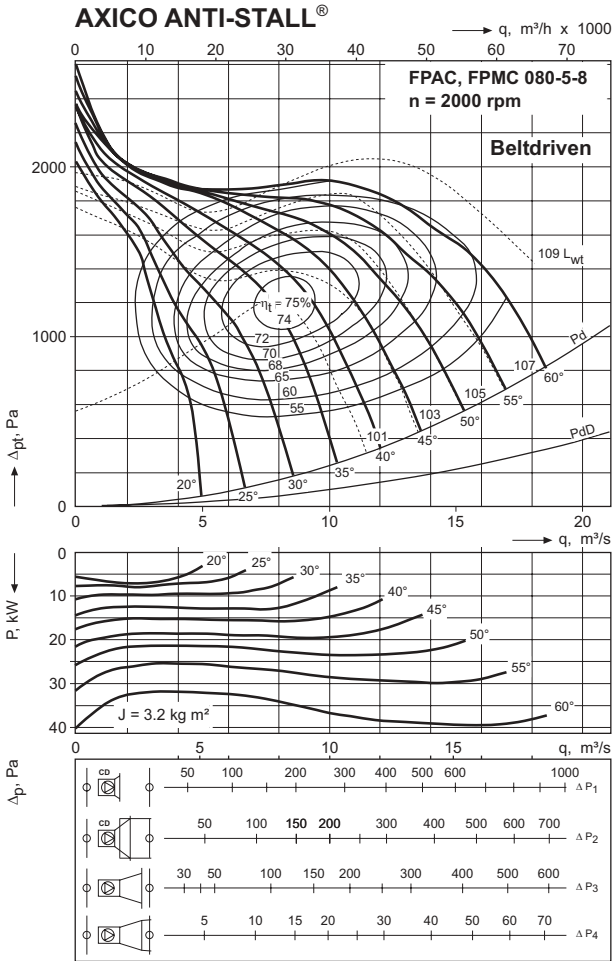

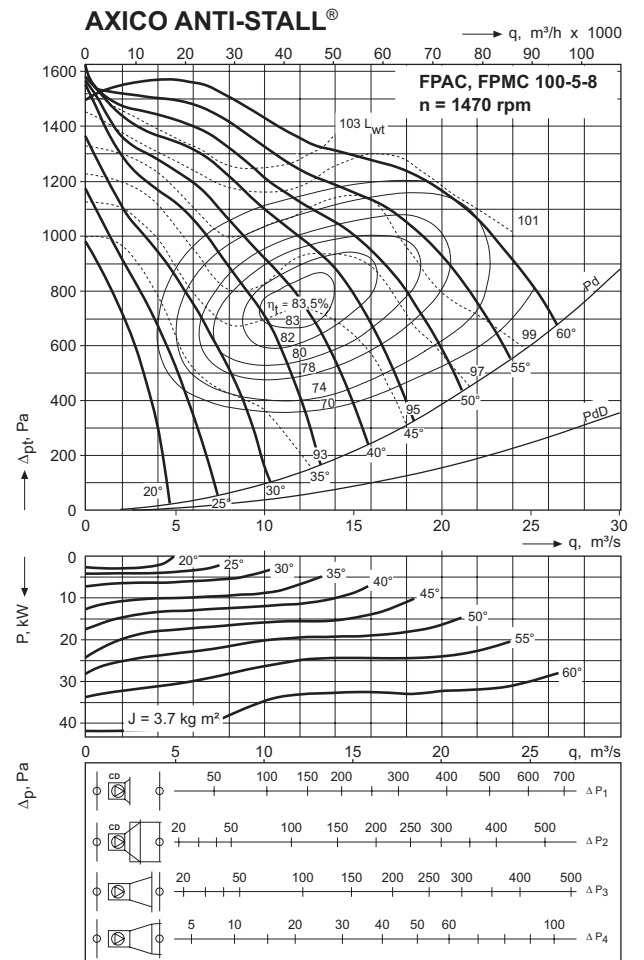
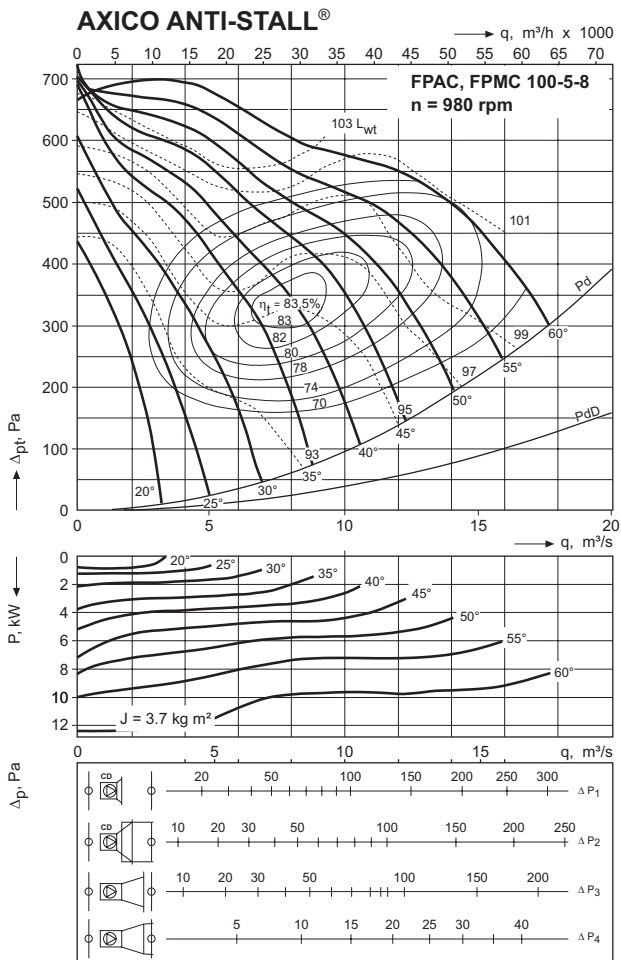
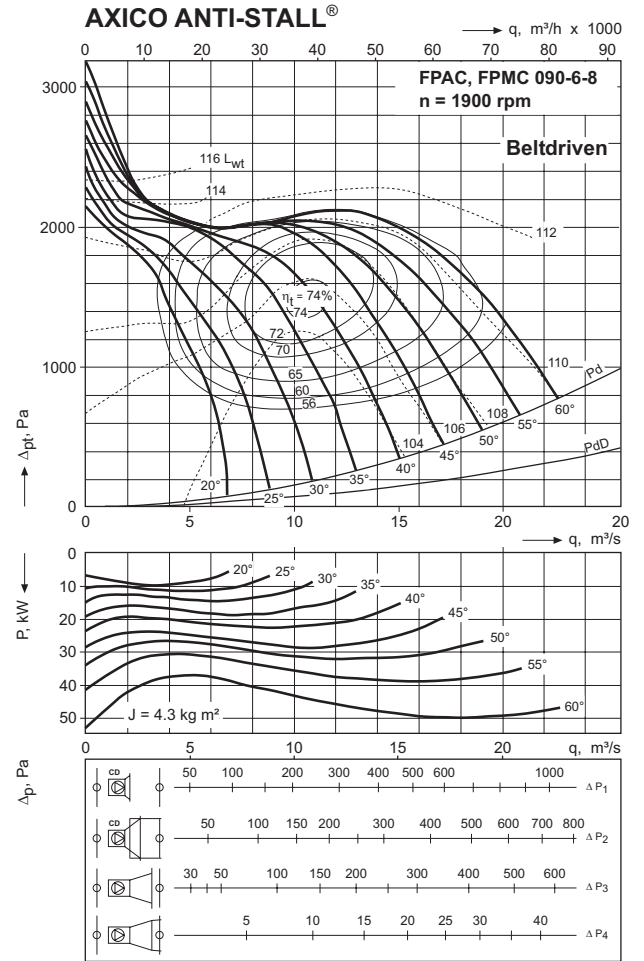
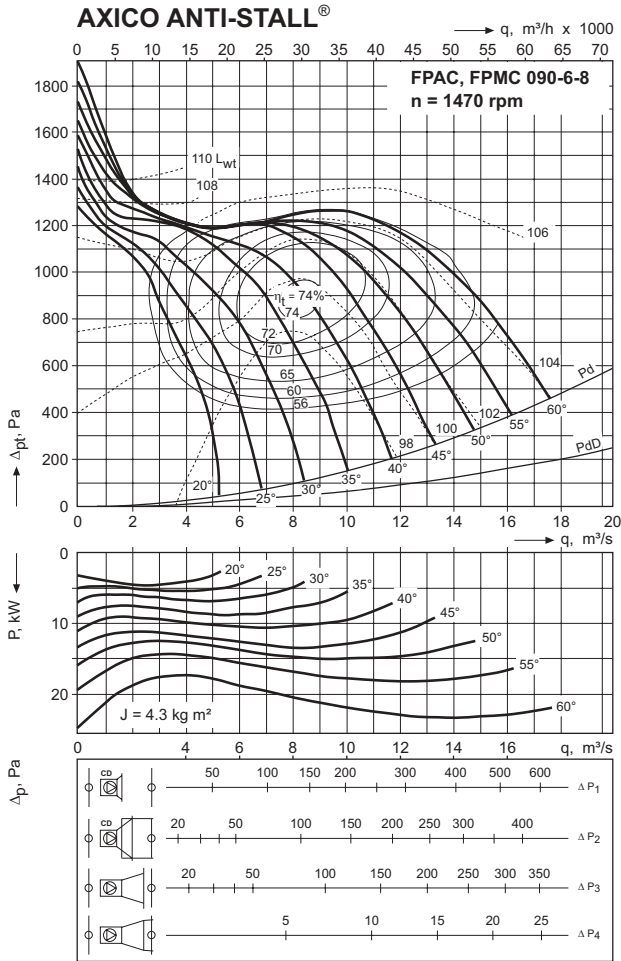

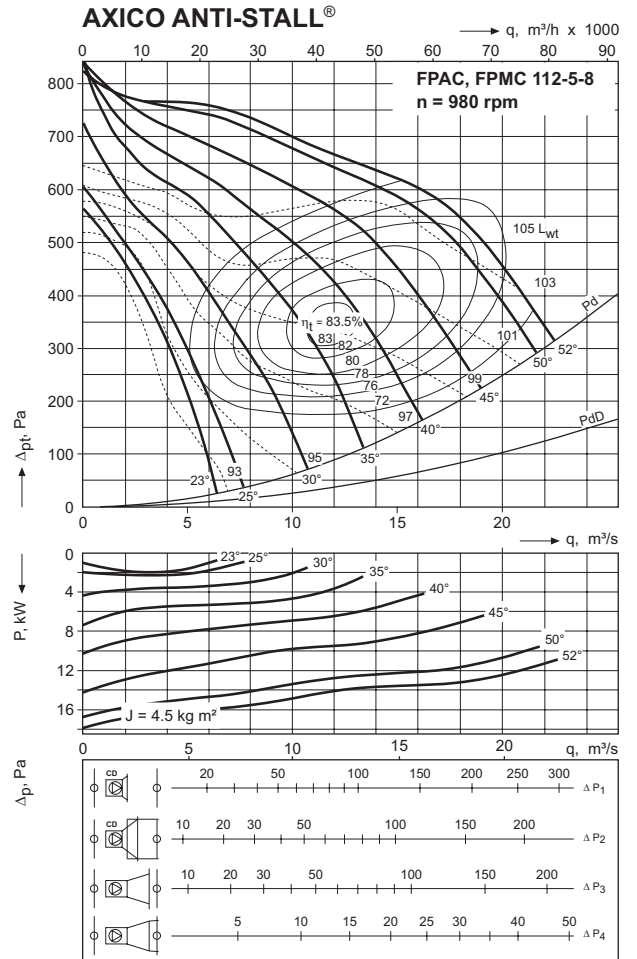
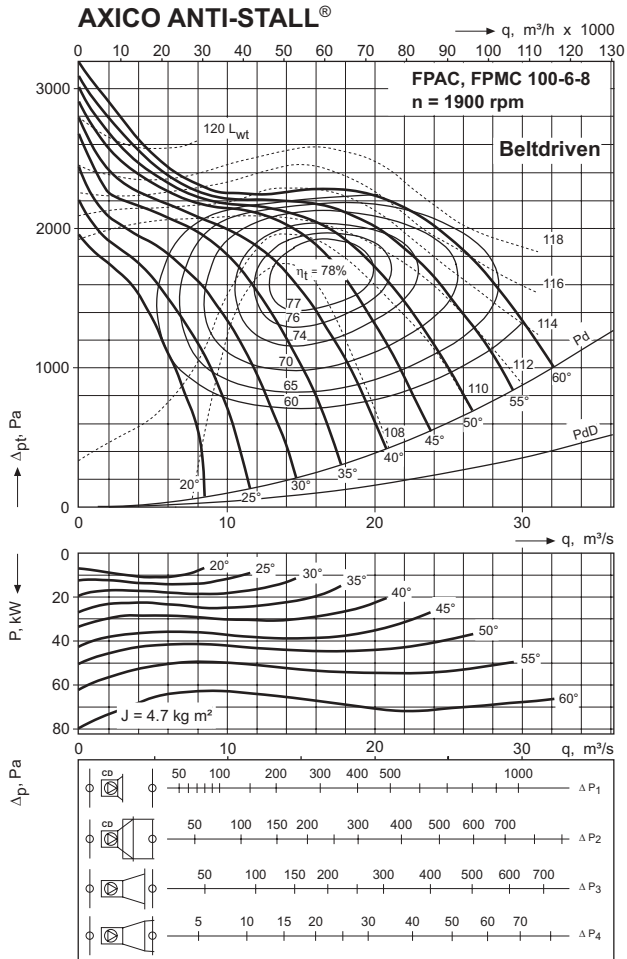
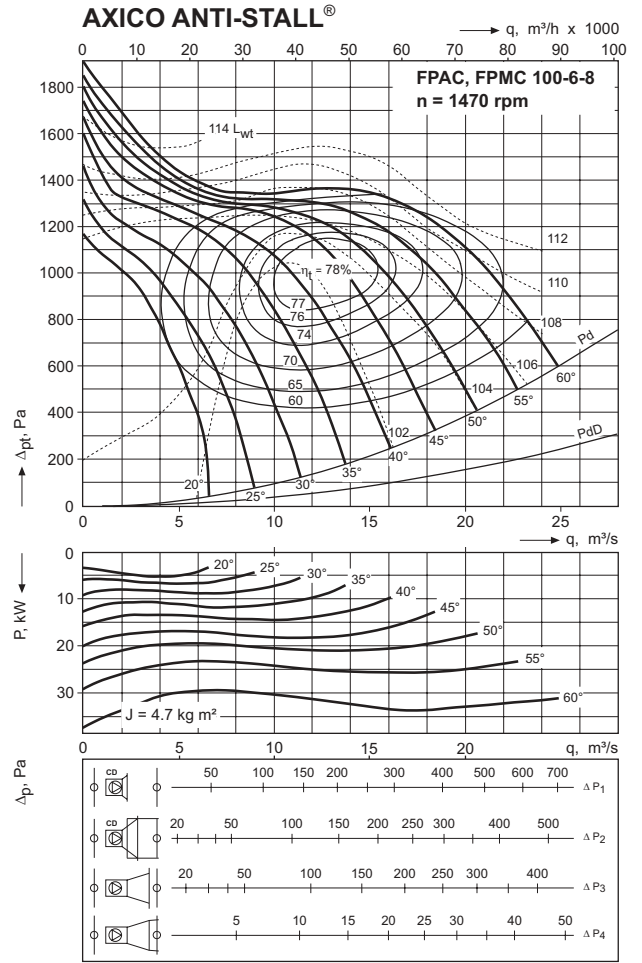
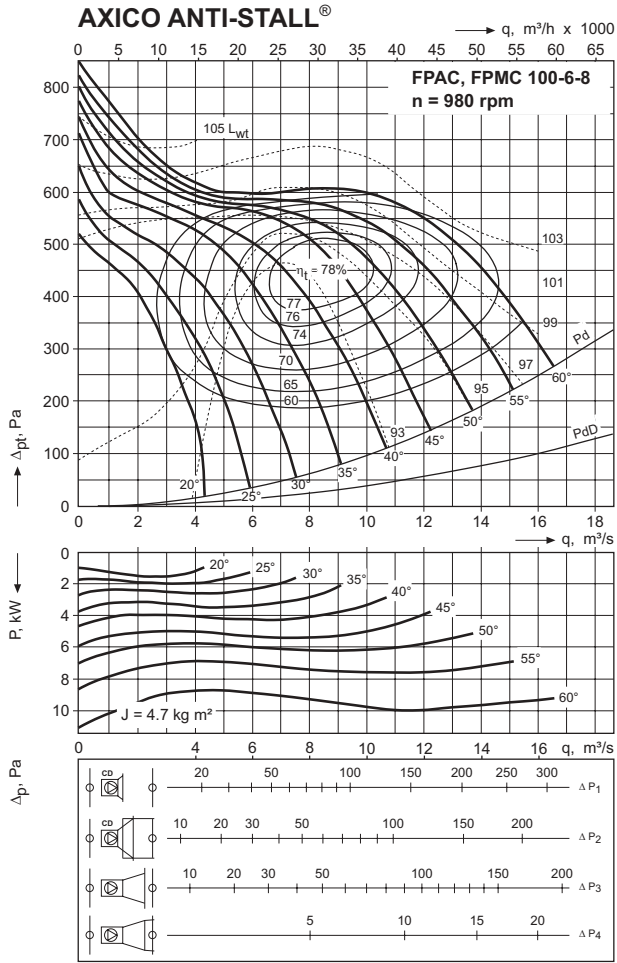

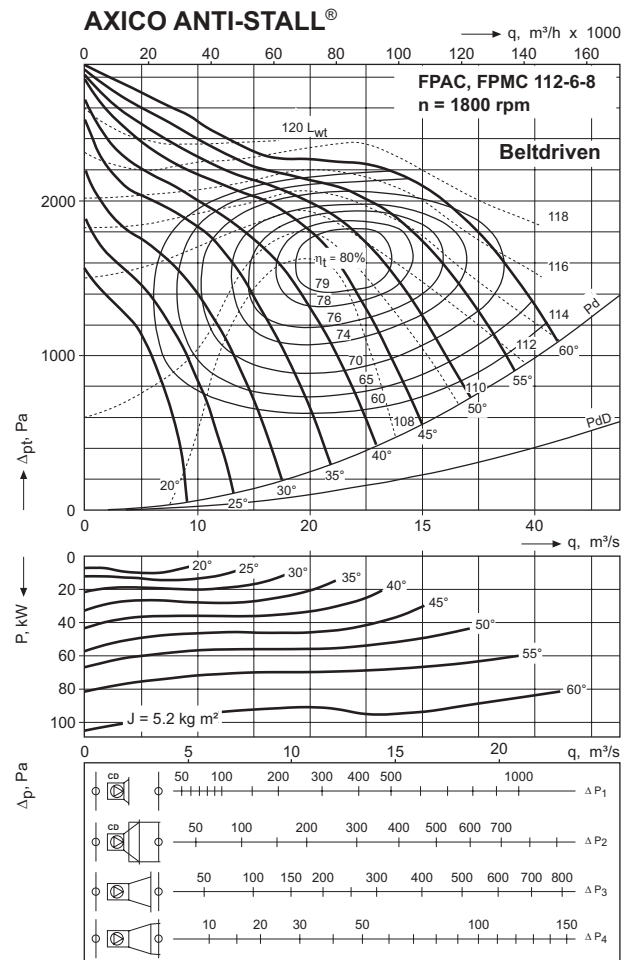
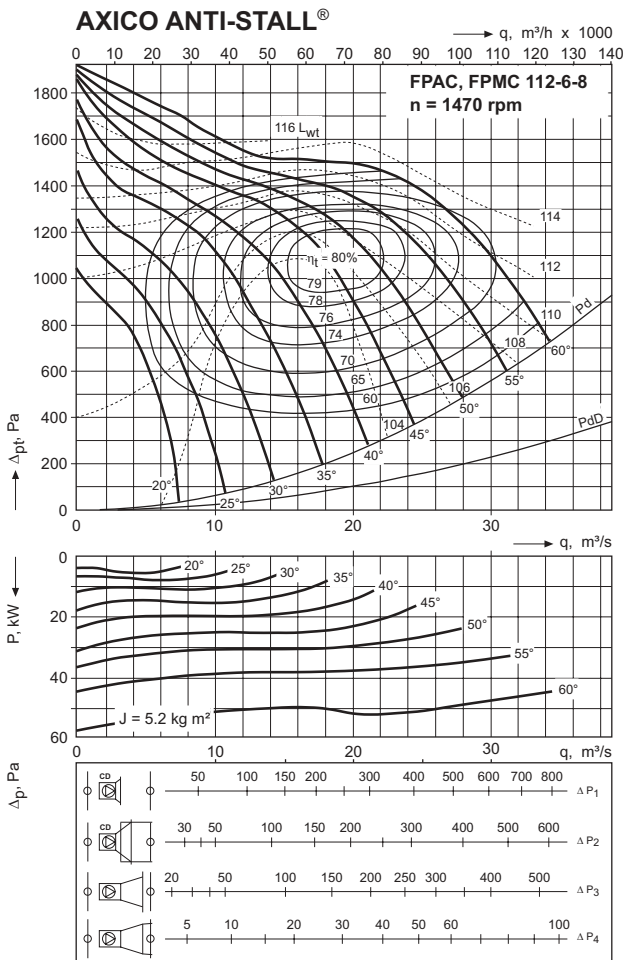
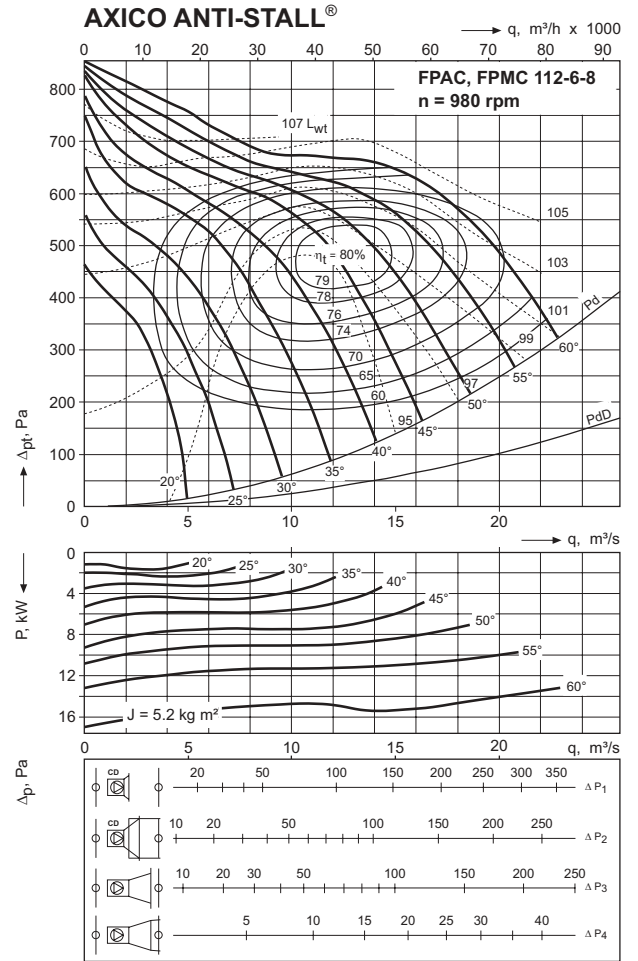
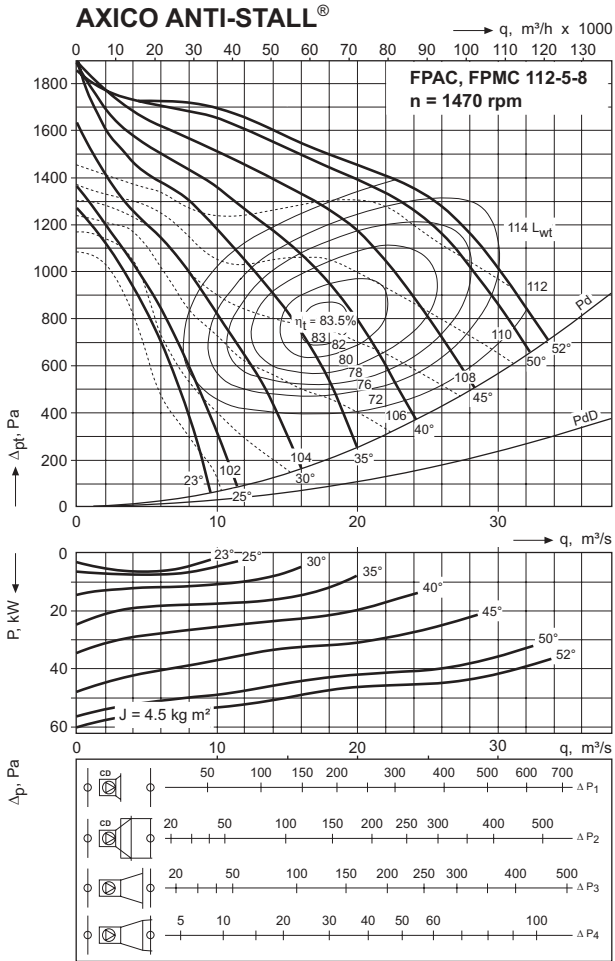

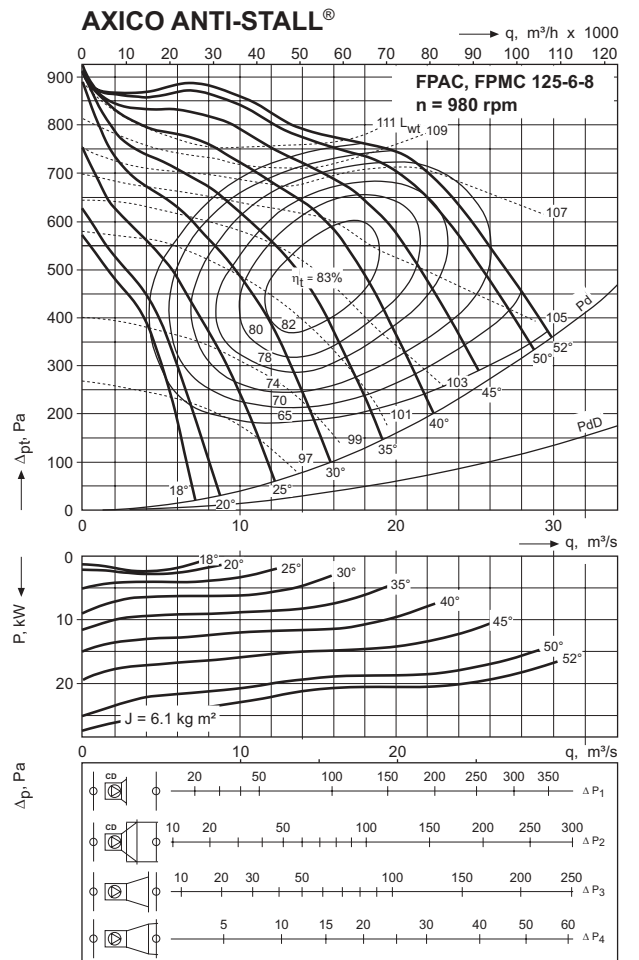
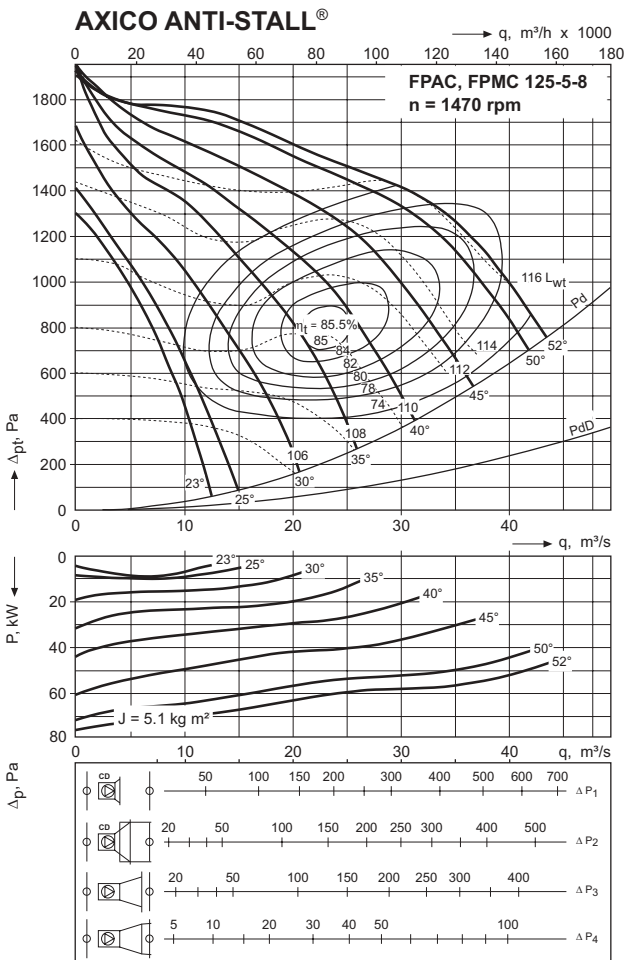
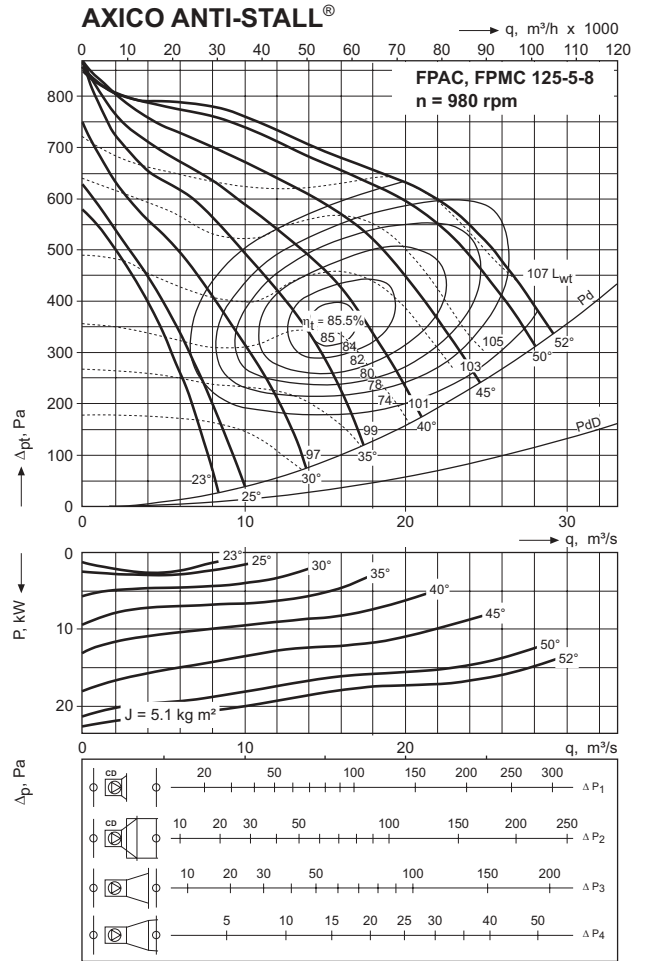
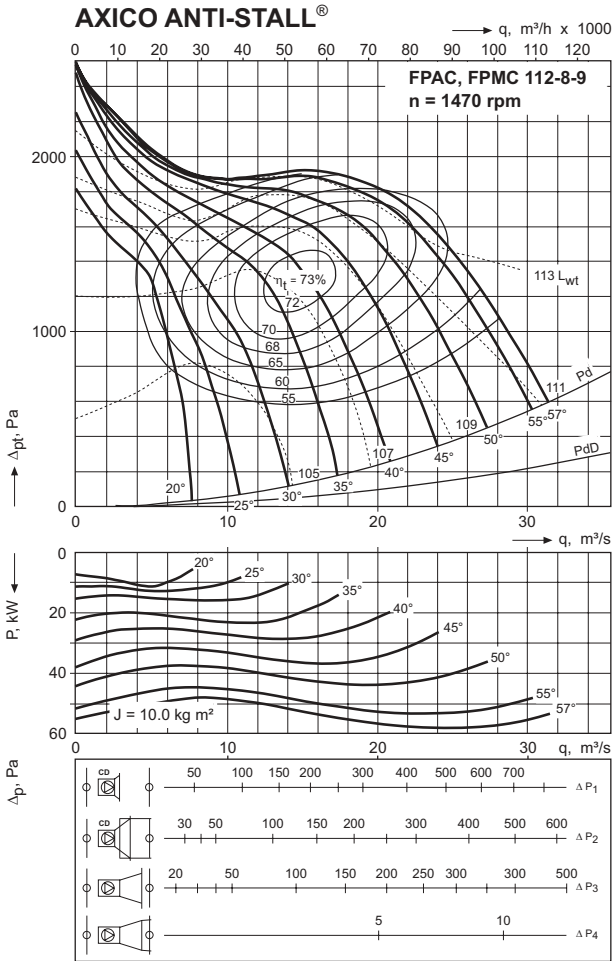



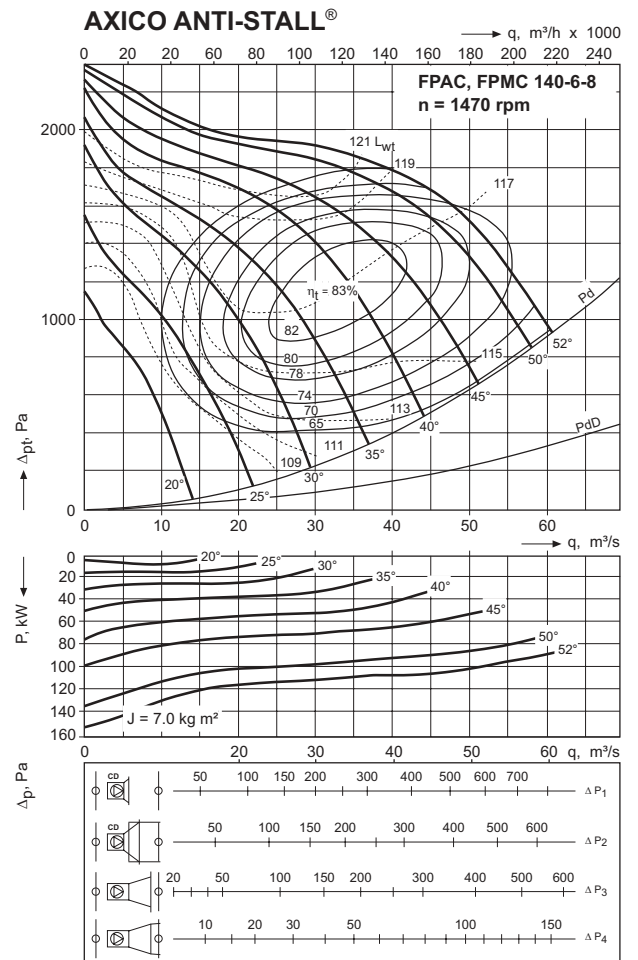
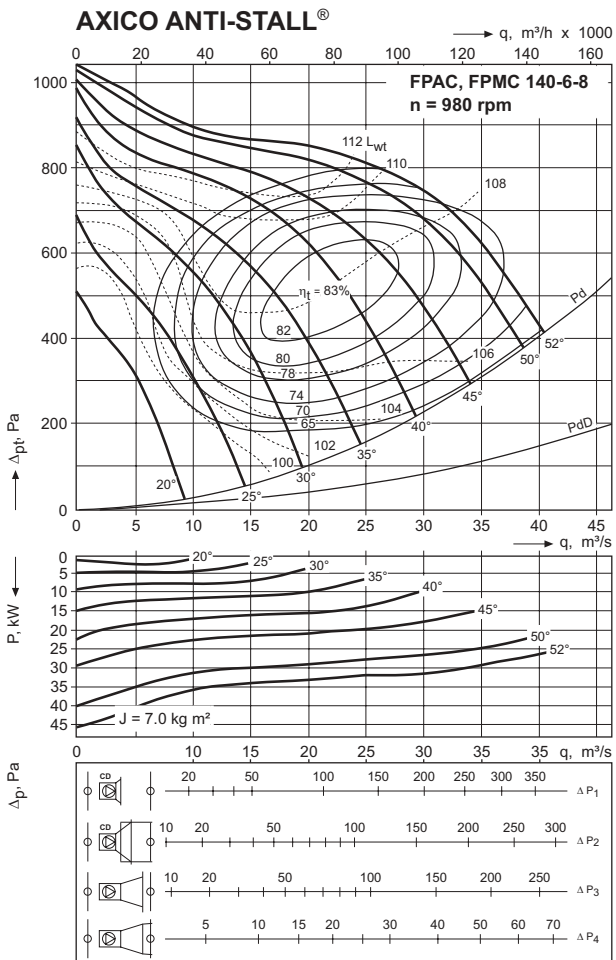
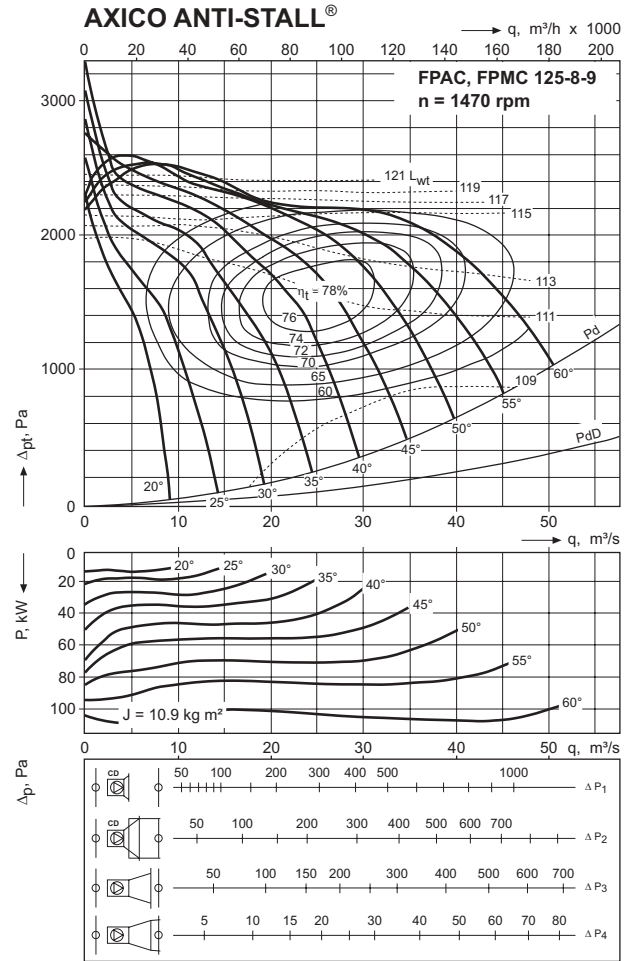
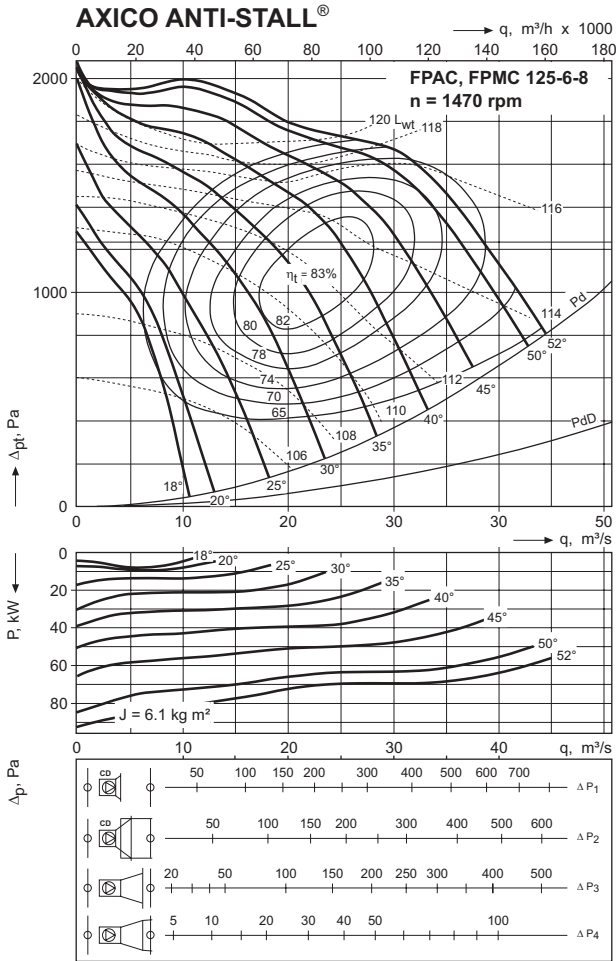

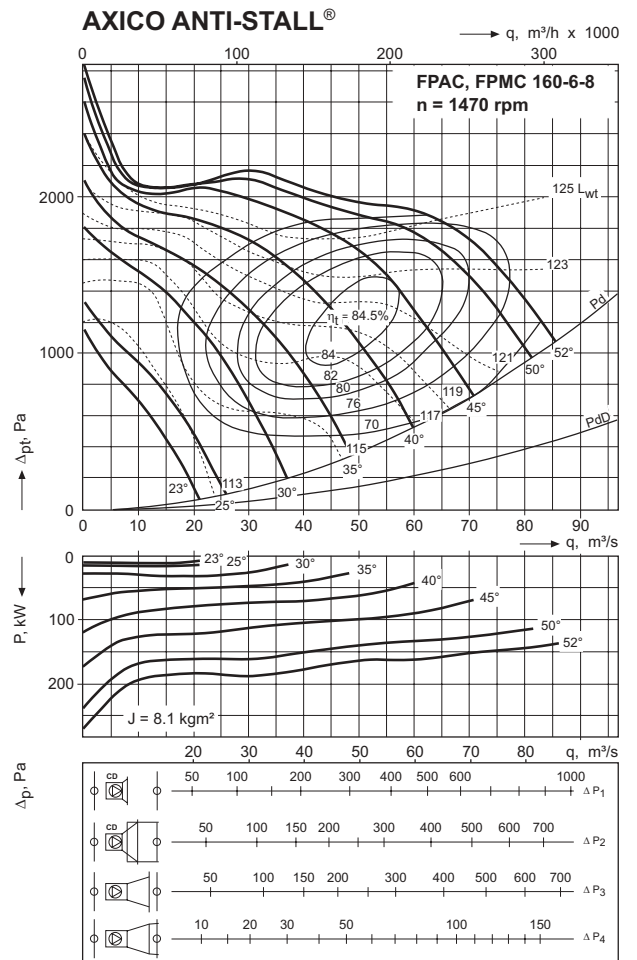
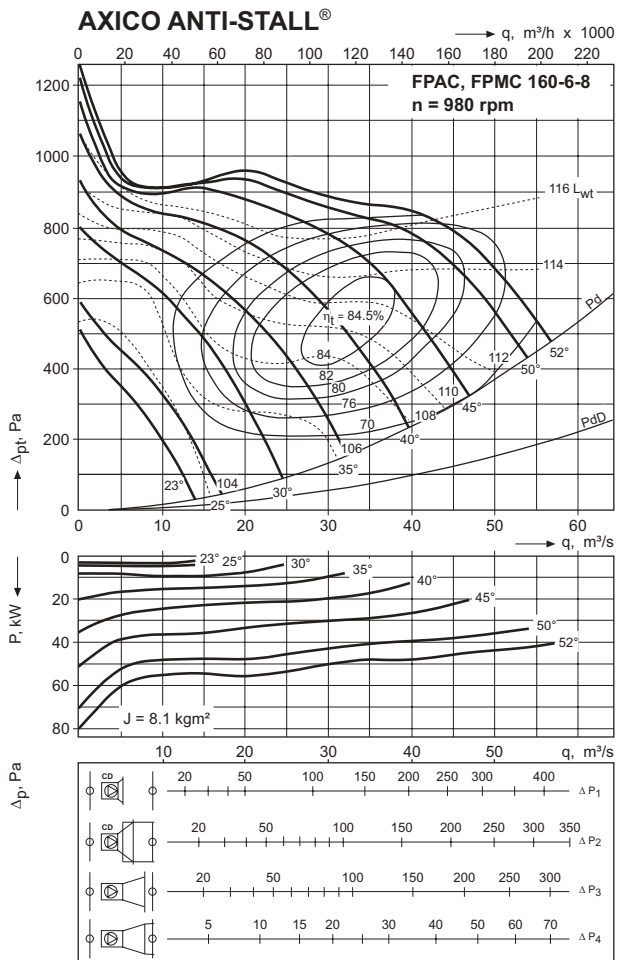
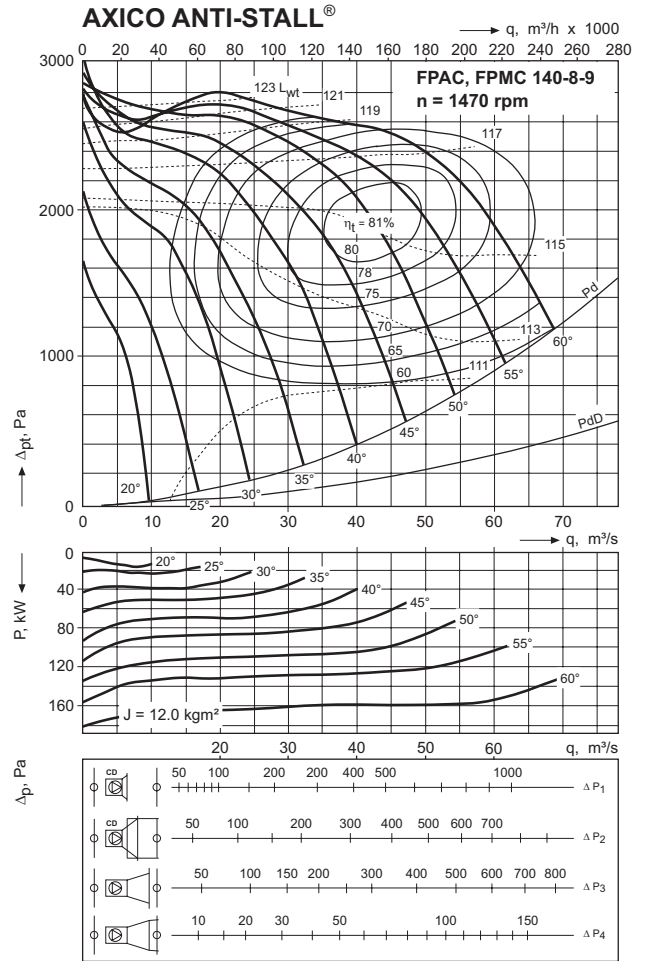
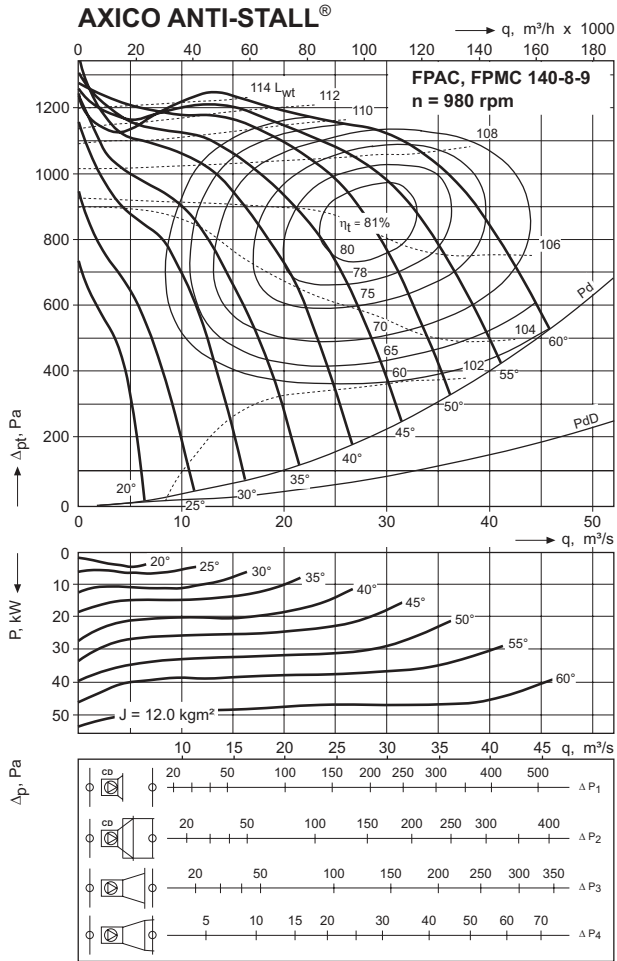

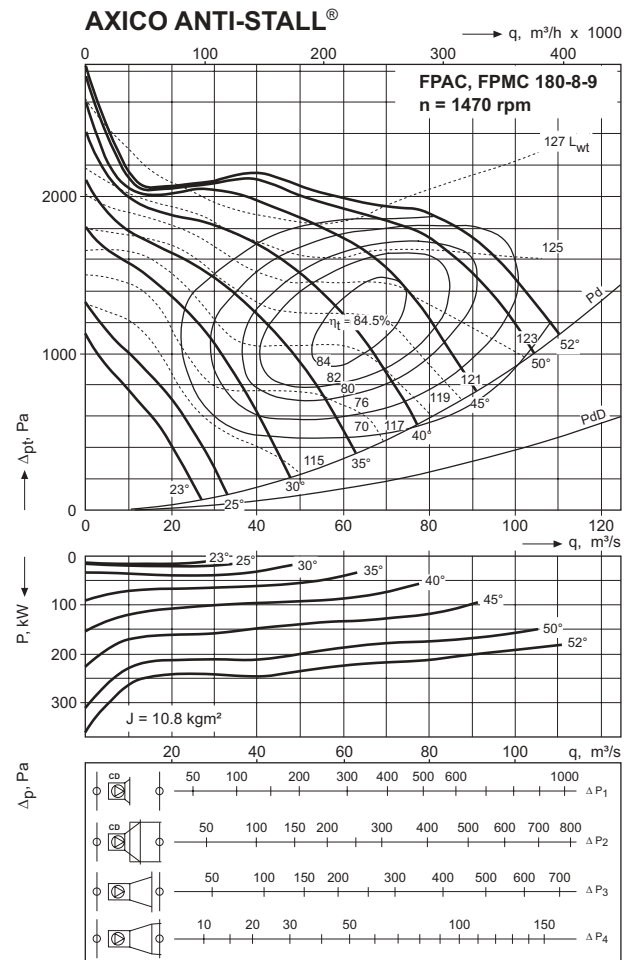
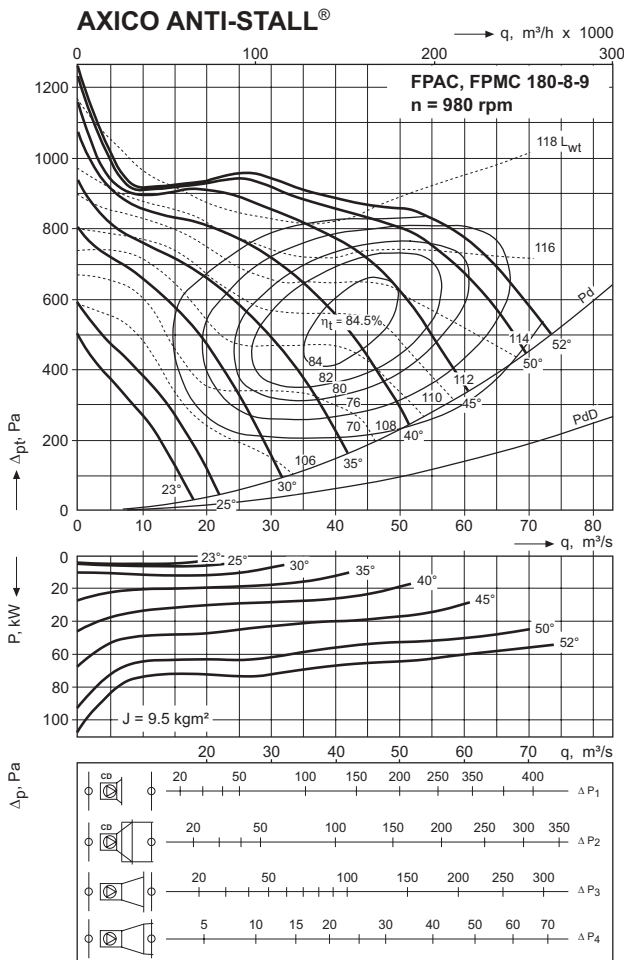
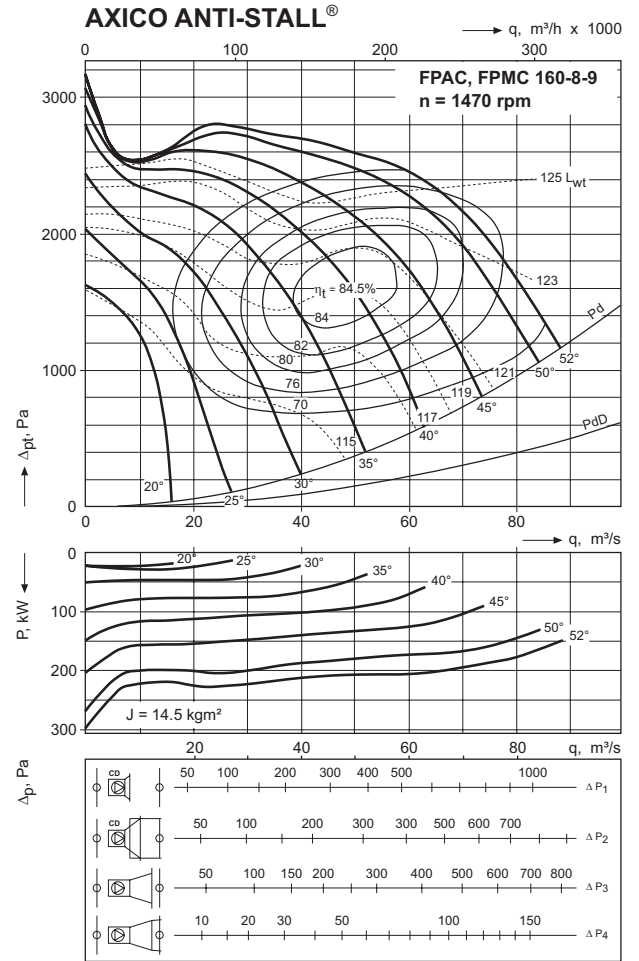
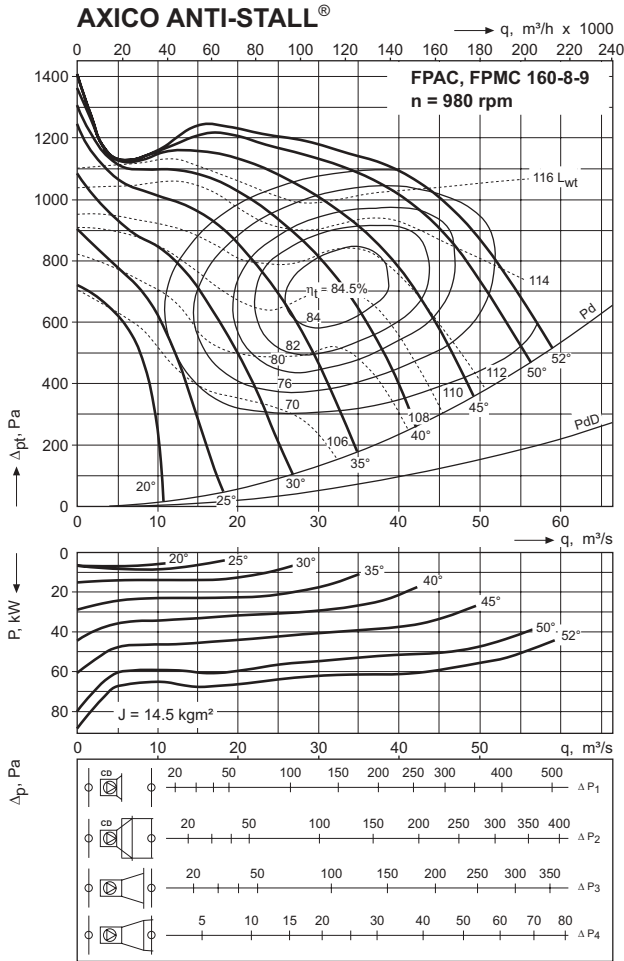

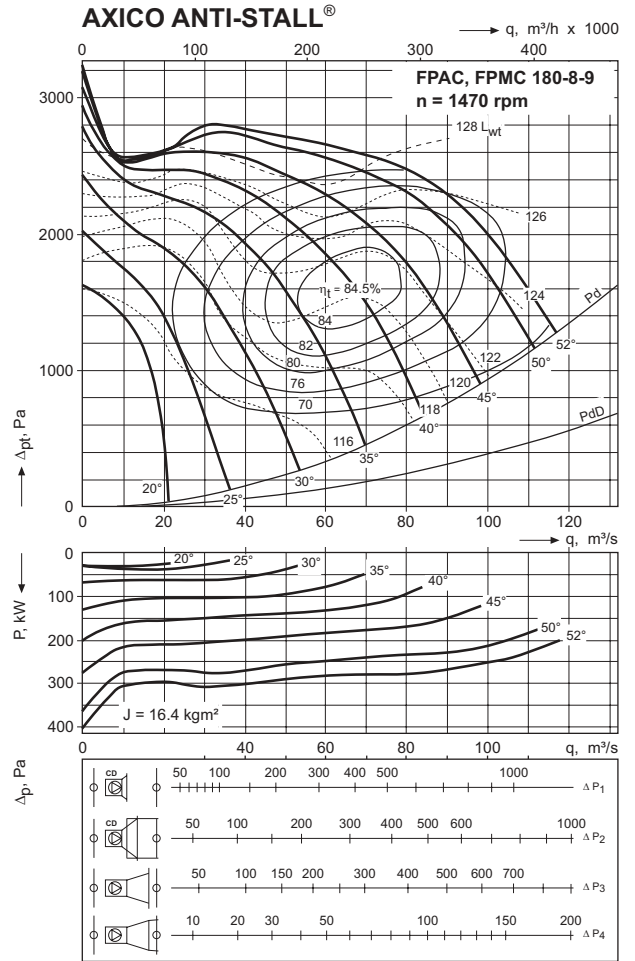
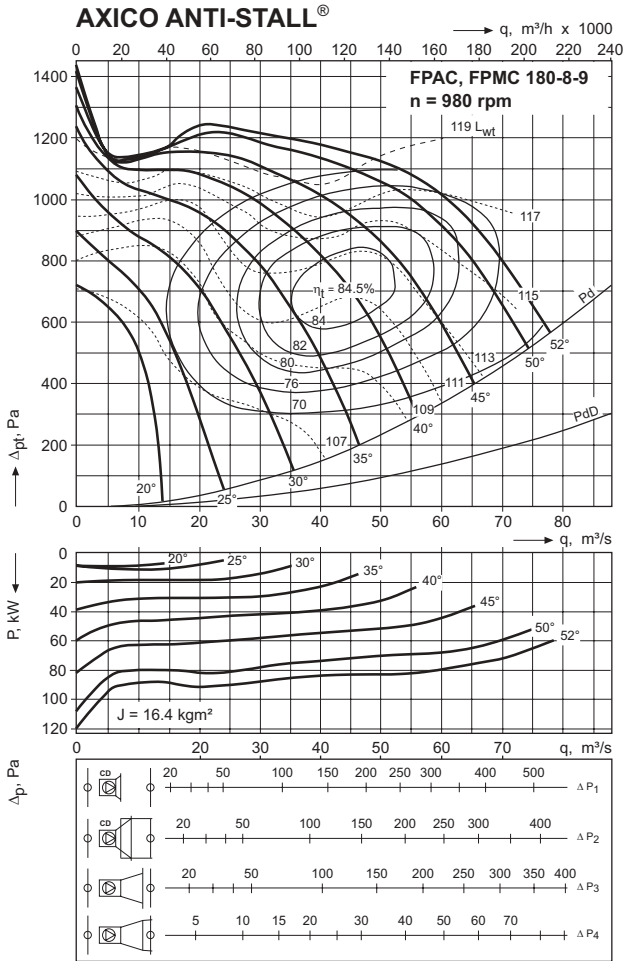

**Motors, arrangements 1, 6 and 7 (to be ordered separately)**

Size bbb	FPAC									FPMC						Motor size as per IEC
	Arrangement (a)									Arrangement (a)						
	1			6			7			1		6		7		
Hub diameter (c)												Motor size as per IEC				
5	6	8	5	6	8	5	6	8	5	6	5		6	5	6	
080	x			x			x			x			x			132 S, M 160 M, L 180 M
090	x	x		x	x		x	x		x	x	x	x	x	x	132 S, M 160 M, L 180M, L 200 L
100	x	x		x	x		x	x		x	x	x	x	x	x	160 M, L 180 M, L 200 L 225 S, M
112	x	x		x	x		x	x		x	x	x	x	x	x	160 M, L 180 M, L 200 L 225 S, M 250 M 280 S 280 M
125	x	x		x	x		x	x		x	x	x	x	x	x	180 M, L 200 L 225 S 225 M 250 M 280 S, M 315 S
140		x		x			x									200 L 225 S, M 250 M 280 S, M 315 S, M, L 355 S
160		x		x			x									225 S, M 250 M 280 S, M 315 S 315 M, L 355 S
180		x		x			x									225 S 225 M 250 M 280 S, M 315 S, M, L 355 S 355 M

**Motors, arrangement 3 (to be ordered separately)**

Fan FPAC, FPMC		Motor size as per IEC	Max fan speed, r/min
Size bbb	Hub c		
080	5	160M - 250M	2000
090	6	180M - 280S	1900
100	6	200L - 280M	1900
112	6	225S - 315S	1800

## Ordering key

**Axial flow fan** (see note)

**FPAC-a-bbb-c-d-e-f**

**Axial flow fan** (see note)

**FPMC-a-bbb-c-d-e-f**

When placing the order, please state the max. blade angle in text (see point 11, page 11)

### Type

AC = pneumatic control  
MC = mechanical control

### Arrangement (a)

- 1 = Impeller mounted on motor shaft
  - for FPAC 080 up to and incl. 125-5-d-e-f  
090 up to and incl. 125-6-d-e-f
  - for FPMC 080 up to and incl. 125-5-d-e-f  
090 up to and incl. 125-6-d-e-f
- 3 = For belt-drive (belt drive to be ordered separately)
  - for FPAC, FPMC 080-5-d-e-f  
090-6-d-e-f  
100-6-d-e-f  
112-6-d-e-f

### 6 = Ducted fan

Horizontal installation:

- for FPAC 080 up to and incl. 125-5-d-e-f  
090 up to and incl. 180-6-d-e-f  
112 up to and incl. 180-8-d-e-f<sup>1)</sup>
- for FPMC 080 up to and incl. 125-5-d-e-f  
090 up to and incl. 125-6-d-e-f

Vertical installation:<sup>2)</sup>

- for FPAC 080 up to and incl. 125-5-d-e-f  
090 up to and incl. 180-6-d-e-f  
112 up to and incl. 180-8-d-e-f

### 7 = Impeller mounted on intermediate shaft

- for FPAC 080 up to and incl. 125-5-d-e-f  
090 up to and incl. 180-6-d-e-f  
112 up to and incl. 180-8-d-e-f
- for FPMC 080 up to and incl. 125-5-d-e-f  
090 up to and incl. 160-6-d-e-f

### Size (bbb)

080, 090, 100, 112, 125, 140, 160, 180

### Hub diameter (c)

5 = 500 mm, 6 = 630 mm, 8 = 800 mm

### Number of blades (d)

Number of blades on size/hub  
8 = 8 blades on 080/5 - 125/5, 090/6 - 180/6  
9 = 10 blades on 112/8 - 180/8

### Motor size (e)<sup>3)</sup>

0 = 132 S, M	5 = 250 M
1 = 160 M, L	6 = 280 S, M
2 = 180 M, L	7 = 315 S, M
3 = 200 L	8 = 315 L
4 = 225 S, M	9 = 355 S, M

### Design (f)

2 = all except FPAC-6, vertical  
3 = FPAC-6, vertical, upward air discharge  
4 = FPAC-6, vertical downward air discharge

### Guide vane diffuser, CD-version (for FPAC)

**FPAZ-01-bbb-c**

### Guide vane diffuser, CD-version (for FPMC)

**FPMZ-01-bbb-c**

### Diffuser, short (after CD guide vane diffuser)

**FPAZ-02-bbb-c**

### Diffuser, long (after fan)

**FPAZ-03-bbb-c**

### Air distributor<sup>4)</sup> (after fan)

**FPAZ-04-bbb-c**

### Air distributor<sup>4)</sup> (after diffusers, see page 6)

**FPAZ-05-bbb-c**

### Transition piece

**FPAZ-06-bbb**

(CD guide vane diffuser - air distributor)

Size = bbb in fan ordering key

Hub diameter = c in fan ordering key

1) Motor with angular contact bearings (for thrust loading on motor) for size/hub dia. 160/8 - 180/8

2) Motor with angular contact bearings (for thrust loading on motor) for upward direction of air discharge. FPMC will be quoted on request.

3) Check that the selected motor is included in the "Motors" table. See page 34.

4) If ordered separately, the air diffusers can be supplied in split condition to facilitate transport.

### Inlet with protective grille (only for arr. 6)

**FPAZ-21-bbb**

Size = bbb in fan ordering key

### Cylindrical silencer

**FPAZ-24-bbb-c**

Size = bbb in fan ordering key

Diameter of core (c)

0 = without core

5, 6, 8 = hub diameter = c in fan ordering key

### Acoustic diffuser (with sound attenuation)

**FPAZ-25-bbb-c**

Size = bbb in fan ordering key

Hub diameter = c in fan ordering key

### Flexible duct (for sound absorber)

**FPAZ-33-bbb**

Size = bbb in fan ordering key

### Counterflange (for diffuser outlet) \*

**EBGA-a-bbb**

### Grouting-in frame (for diffuser outlet) \*

**EBGV-a-bbb**

Materials and finish (a)

0 = unpainted, 1 = steel, painted

Size = bbb in fan ordering key. see \* below

\* NB. The outlet of FPAZ-02, 03 and -25 diffusers is two sizes larger than the fan connection.

### Actuator

**FPMZ-07-b**

### Actuator

**FPMZ-09-b**

### Actuator

**FPMZ-13-b**

See table on page 28

### Electro-pneumatic positioner

**FPAZ-14**

### Pressure control equipment

**FPAZ-16-bb-c**

Control range (bb): 05 = 0-500 Pa  
10 = 50-1000 Pa  
20 = 100-2000 Pa

Version (c): 1 = For one fan

2 = For two fans

### Pressure control equipment

**FPMZ-16-bb-c-d**

Control range (bb): 05 = 0-500 Pa  
10 = 50-1000 Pa  
20 = 100-2000 Pa

Version (c): 1 = For one fan

2 = For two fans

Type (d): 1 = Increase-Decrease

2 = 2-10V DC

### Flow measurement transmitter

**FPAZ-17**

For particulars of the measuring range, get in touch with your nearest Fläkt Woods AB representative

### Flow measuring tapping

**FPAZ-18-bb**

b = code suffix "a" in the fan code

### Control equipment for air flow control

**FPAZ-70-bb**

Control range (bb): 05 = 0-500 Pa  
10 = 50-1000 Pa  
20 = 100-2000 Pa

### Blade pitch indicator for FPAC

**FPAZ-19**

### Blade pitch indicator for FPMC

**FPMZ-19**

### Note

The motor should be specified separately as described on pages 34-39. The fans are designed for being driven by ABB motors, but a quotation can be submitted for equipping the fan with a motor of any other manufacture. However, if a different motor is selected, the order must always be accompanied by a drawing showing the dimensions of the relevant motor. In the case of arrangements 1 and 6, the outside dimensions of the motor must not be larger than those of the corresponding ABB motor, and the thrust-carrying capacity of the bearings must not be lower. For arrangements 1 and 6 the outside dimensions of the motor must not be larger than the hub diameter of the corresponding fan, since the fan performance may otherwise be affected. This applies to motor sizes IEC 225, 250 and 280 for hub diameters 5, 6 and 8 respectively. For arrangement 6, sizes 280 and larger motors must have permanently connected cables without terminal box in accordance with Fläkt Woods AB drawing no. V 2608656.

**Acoustic data**

The acoustic particulars are valid within the tolerances specified by AMCA for operating points within the marked efficiency lines and for blade angles up to 55° (see the fan charts).

The total A-weighted sound power level to the ducting for arrangements 1 and 7 (L<sub>wt</sub>) can be read from the fan charts.

Other sound data can be calculated on the basis of L<sub>wt</sub>.

The sound data for arrangement 3 and for arrangements 1 and 6 with large motors ( see remarks on page 21) can be obtained on request from your nearest Fläkt Woods AB representative.

**Octave band levels**

The following method of calculation is used for obtaining the acoustic data at octave band levels for arrangements 1, 6 and 7.

L<sub>wt</sub> = total A-weighted sound power level to the ducting for arrangement 1 or 7. Read from the chart.

L<sub>wa</sub> = sound power level per octave band to the ducting.

L<sub>wb</sub> = sound power level per octave band to the surroundings for a free inlet installation.

L<sub>wc</sub> = sound power level per octave band to the surroundings for a ducted fan. Arrangement 6.

**Formulae:**

$L_{wa} = L_{wt} + k_{oka}$

$L_{wb} = L_{wt} + k_{okb}$

$L_{wc} = L_{wa} + k_c$

**Total sound levels**

If only A-weighted total levels are required, a simple method of calculation can be employed.

L<sub>wt</sub> = total A-weighted sound power level to the ducting for arrangement 1 or 7. Read from the chart.

L<sub>wbt</sub> = total A-weighted sound power level to the surroundings for a free inlet installation. Arrangement 1 or 7.

L<sub>wct</sub> = total A-weighted sound power level to the surroundings for a ducted fan. Arrangement 6.

L<sub>wdt</sub> = total A-weighted sound power level to the ducting with a sound absorber or sound-attenuating diffuser.

k<sup>c</sup><sub>dBA</sub> = attenuation in dB(A) of the fan casing.

k<sup>d</sup><sub>dBA</sub> = attenuation in dB(A) of the FPAZ-24 sound absorber and FPAZ-25 diffuser.

L<sub>wt</sub> and L<sub>wbt</sub> for arrangement 6 is slightly higher (max. 1 dB) than those for arrangement 1.

**Formulae:**

$L_{wbt} = L_{wt}$

$L_{wct} = L_{wt} - k^c_{dBA}$

$L_{wdt} = L_{wt} - k^d_{dBA}$

**Correction factors for sound to connected ducting and the surroundings of free inlet installation.**

**980 rpm fan speed, arrangements 1 and 7**

Size bbb-c	Sound path	koka and kokb, dB							
		Octave band, mid-frequency, Hz							
		63	125	250	500	1000	2000	4000	8000
080-5	duct (a)	+3	-2	-3	-2	-4	-10	-15	-19
	inlet (b)	-2	-2	-3	-2	-4	-10	-14	-16
090-5	duct (a)	-1	-5	-5	-1	-4	-9	-15	-22
	inlet (b)	-5	-5	-5	-1	-4	-9	-14	-19
090-6	duct (a)	-4	-4	-2	-5	-5	-7	-10	-14
	inlet (b)	-8	-4	-2	-5	-5	-7	-9	-11
100-5	duct (a)	-6	-9	-8	-1	-4	-9	-16	-24
	inlet (b)	-10	-9	-8	-1	-4	-9	-15	-21
100-6	duct (a)	-6	-6	-5	-4	-4	-8	-11	-15
	inlet (b)	-10	-6	-5	-4	-4	-8	-10	-12
112-5	duct (a)	-8	-10	-9	-1	-4	-10	-16	-23
	inlet (b)	-11	-10	-9	-1	-4	-10	-15	-20
112-6	duct (a)	-7	-8	-7	-3	-4	-8	-13	-17
	inlet (b)	-10	-8	-7	-3	-4	-8	-12	-14
112-8	duct (a)	+1	-3	-6	-2	-4	-9	-13	-17
	inlet (b)	-2	-3	-6	-2	-4	-9	-12	-14
125-5	duct (a)	-11	-10	-10	-1	-4	-10	-17	-22
	inlet (b)	-14	-10	-10	-1	-4	-10	-16	-19
125-6	duct (a)	-9	-9	-10	-2	-4	-9	-14	-19
	inlet (b)	-12	-9	-10	-2	-4	-9	-13	-16
125-8	duct (a)	-4	-2	-7	-2	-4	-9	-14	-19
	inlet (b)	-7	-2	-7	-2	-4	-9	-13	-16
140-6	duct (a)	-14	-10	-9	-2	-4	-8	-15	-20
	inlet (b)	-16	-10	-9	-2	-4	-8	-14	-17
140-8	duct (a)	-5	-4	-8	-3	-4	-8	-13	-19
	inlet (b)	-7	-4	-8	-3	-4	-8	-12	-16
160-6	duct (a)	-18	-10	-9	-3	-4	-8	-15	-21
	inlet (b)	-19	-10	9	-3	-4	-8	-14	-18
160-8	duct (a)	-15	-8	-10	-4	-3	-8	-14	-18
	inlet (b)	-16	-8	-10	-4	-3	-8	-13	-15
180-6	duct (a)	-20	-6	-6	-3	-3	-7	-15	-21
	inlet (b)	-20	-6	-6	-3	-3	-7	-14	-18
180-8	duct (a)	-18	-7	-9	-5	-3	-7	-14	-18
	inlet (b)	-18	-7	-9	-5	-3	-7	-13	-15

**980 rpm fan speed, arrangement 6**

Size bbb-c	Sound path	koka and kokb, dB							
		Octave band, mid-frequency, Hz							
		63	125	250	500	1000	2000	4000	8000
080-5	duct (a)	+3	+2	-1	-2	-4	-10	-15	-19
	inlet (b)	-2	+2	-1	-2	-4	-10	-14	-16
090-5	duct (a)	-1	-1	-3	-1	-4	-9	-15	-22
	inlet (b)	-5	-1	-3	-1	-4	-9	-14	-19
090-6	duct (a)	-4	0	0	-5	-5	-7	-10	-14
	inlet (b)	-8	0	0	-5	-5	-7	-9	-11
100-5	duct (a)	-6	-5	-6	-1	-4	-9	-16	-24
	inlet (b)	-10	-5	-6	-1	-4	-9	-15	-21
100-6	duct (a)	-6	-2	-3	-4	-4	-8	-11	-15
	inlet (b)	-10	-2	-3	-4	-4	-8	-10	-12
112-5	duct (a)	-8	-6	-7	-1	-4	-10	-16	-23
	inlet (b)	-11	-6	-7	-1	-4	-10	-15	-20
112-6	duct (a)	-7	-4	-5	-3	-4	-8	-13	-17
	inlet (b)	-10	-4	-5	-3	-4	-8	-12	-14
112-8	duct (a)	+1	+1	-4	-2	-4	-9	-13	-17
	inlet (b)	-2	+1	-4	-2	-4	-9	-12	-14
125-5	duct (a)	-11	-6	-8	-1	-4	-10	-17	-22
	inlet (b)	-14	-6	-8	-1	-4	-10	-16	-19
125-6	duct (a)	-9	-5	-8	-2	-4	-9	-14	-19
	inlet (b)	-12	-5	-8	-2	-4	-9	-13	-16
125-8	duct (a)	-4	+2	-5	-2	-4	-9	-14	-19
	inlet (b)	-7	+2	-5	-2	-4	-9	-13	-16
140-6	duct (a)	-14	-6	-7	-2	-4	-8	-15	-20
	inlet (b)	-16	-6	-7	-2	-4	-8	-14	-17
140-8	duct (a)	-5	0	-6	-3	-4	-8	-13	-19
	inlet (b)	-7	0	-6	-3	-4	-8	-12	-16
160-6	duct (a)	-18	-8	-8	-3	-4	-8	-15	-21
	inlet (b)	-19	-8	8	-3	-4	-8	-14	-18
160-8	duct (a)	-15	-6	-9	-4	-3	-8	-14	-18
	inlet (b)	-16	-6	-9	-4	-3	-8	-13	-15
180-6	duct (a)	-20	-4	-5	-3	-3	-7	-15	-21
	inlet (b)	-20	-4	-5	-3	-3	-7	-14	-18
180-8	duct (a)	-18	-5	-8	-5	-3	-7	-14	-18
	inlet (b)	-18	-5	-8	-5	-3	-7	-13	-15

**Correction factors for sound to connected ducting and the surroundings of free inlet installation.**

**1470 rpm fan speed, arrangements 1 and 7**

Size bbb-c	Sound path	koka and kokb, dB Octave band, mid-frequency, Hz							
		63	125	250	500	1000	2000	4000	8000
080-5	duct (a)	-3	-8	-6	-3	-4	-8	-13	-15
	inlet (b)	-8	-8	-6	-3	-4	-8	-12	-12
090-5	duct (a)	-6	-10	-8	-3	-3	-9	-14	-17
	inlet (b)	-10	-10	-8	-3	-3	-9	-13	-14
090-6	duct (a)	-4	-6	-5	-3	-4	-8	-12	-16
	inlet (b)	-8	-6	-5	-3	-4	-8	-11	-13
100-5	duct (a)	-9	-12	-11	-4	-2	-9	-14	-18
	inlet (b)	-13	-12	-11	-4	-2	-9	-13	-15
100-6	duct (a)	-7	-9	-6	-4	-4	-8	-12	-16
	inlet (b)	-11	-9	-6	-4	-4	-8	-11	-13
112-5	duct (a)	-11	-13	-9	-5	-3	-8	-14	-18
	inlet (b)	-14	-13	-9	-5	-3	-8	-13	-15
112-6	duct (a)	-10	-11	-7	-5	-3	-8	-12	-17
	inlet (b)	-13	-11	-7	-4	-3	-8	-11	-14
112-8	duct (a)	-7	-10	-5	-4	-3	-9	-13	-17
	inlet (b)	-10	-10	-5	-4	-3	-9	-12	-14
125-5	duct (a)	-13	-15	-8	-6	-3	-7	-13	-18
	inlet (b)	-16	-15	-8	-6	-3	-7	-12	-15
125-6	duct (a)	-13	-14	-7	-6	-3	-7	-13	-17
	inlet (b)	-16	-14	-7	-6	-3	-7	-12	-14
125-8	duct (a)	-8	-8	-6	-6	-4	-7	-12	-17
	inlet (b)	-11	-8	-6	-6	-4	-7	-11	-14
140-6	duct (a)	-16	-15	-9	-6	-3	-7	-11	-16
	inlet (b)	-18	-15	-9	-6	-3	-7	-10	-13
140-8	duct (a)	-9	-9	-8	-7	-4	-6	-10	-16
	inlet (b)	-11	-9	-8	-7	-4	-6	-9	-13
160-6	duct (a)	-21	-14	-11	-7	-4	-6	-11	-18
	inlet (b)	-22	-14	11	-7	-4	-6	-10	-15
160-8	duct (a)	-17	-14	-10	-8	-4	-6	-11	-16
	inlet (b)	-18	-14	-10	-8	-4	-6	-10	-13
180-6	duct (a)	-22	-12	-10	-5	-4	-6	-11	-18
	inlet (b)	-22	-12	-10	-5	-4	-6	-10	-15
180-8	duct (a)	-19	-16	-9	-9	-5	-4	-9	-15
	inlet (b)	-19	-16	-9	-9	-5	-4	-8	-12

**1470 rpm fan speed, arrangement 6**

Size bbb-c	Sound path	koka and kokb, dB Octave band, mid-frequency, Hz							
		63	125	250	500	1000	2000	4000	8000
080-5	duct (a)	-3	-4	-2	0	-4	-8	-13	-15
	inlet (b)	-8	-4	-2	0	-4	-8	-12	-12
090-5	duct (a)	-6	-6	-4	0	-3	-9	-14	-17
	inlet (b)	-10	-6	-4	0	-3	-9	-13	-14
090-6	duct (a)	-4	-2	-1	0	-4	-8	-12	-16
	inlet (b)	-8	-2	-1	0	-4	-8	-11	-13
100-5	duct (a)	-9	-8	-7	-1	-2	-9	-14	-18
	inlet (b)	-13	-8	-7	-1	-2	-9	-13	-15
100-6	duct (a)	-7	-5	-2	-1	-4	-8	-12	-16
	inlet (b)	-11	-5	-2	-1	-4	-8	-11	-13
112-5	duct (a)	-11	-9	-5	-2	-3	-8	-14	-18
	inlet (b)	-14	-9	-5	-2	-3	-8	-13	-15
112-6	duct (a)	-10	-7	-3	-2	-3	-8	-12	-17
	inlet (b)	-13	-7	-3	-2	-3	-8	-11	-14
112-8	duct (a)	-7	-6	-1	-1	-3	-9	-13	-17
	inlet (b)	-10	-6	-1	-1	-3	-9	-12	-14
125-5	duct (a)	-13	-11	-4	-3	-3	-7	-13	-18
	inlet (b)	-16	-11	-4	-3	-3	-7	-12	-15
125-6	duct (a)	-13	-10	-3	-3	-3	-7	-13	-17
	inlet (b)	-16	-10	-3	-3	-3	-7	-12	-14
125-8	duct (a)	-8	-4	-2	-3	-4	-7	-12	-17
	inlet (b)	-11	-4	-2	-3	-4	-7	-11	-14
140-6	duct (a)	-16	-11	-5	-3	-3	-7	-11	-16
	inlet (b)	-18	-11	-5	-3	-3	-7	-10	-13
140-8	duct (a)	-9	-5	-4	-4	-4	-6	-10	-16
	inlet (b)	-11	-5	-4	-4	-4	-6	-9	-13
160-6	duct (a)	-21	-12	-9	-5	-4	-6	-11	-18
	inlet (b)	-22	-12	9	-5	-4	-6	-10	-15
160-8	duct (a)	-17	-12	-8	-6	-4	-6	-11	-16
	inlet (b)	-18	-12	-8	-6	-4	-6	-10	-13
180-6	duct (a)	-22	-10	-8	-4	-4	-6	-11	-18
	inlet (b)	-22	-10	-8	-4	-4	-6	-10	-15
180-8	duct (a)	-19	-14	-7	-8	-5	-4	-9	-15
	inlet (b)	-19	-14	-7	-8	-5	-4	-8	-12

**Correction factors: for sound to the surroundings of ducted fan.**

The fan is ducted on both sides.

Accessories	k <sub>C</sub> , dB Octave band, mid-frequency, Hz								k <sub>C</sub> <sub>dBA</sub> dB(A)
	63	125	250	500	1000	2000	4000	8000	
Standard	-9	-9	-9	-11	-10	-11	-10	-13	10
Standard but with acoustic connection ducts <sup>1)</sup>	-9	-11	-17	-16	-13	-13	-10	-13	13

<sup>1)</sup> Quotations for acoustic connection ducts (heavy-duty rubber ducts that help to reduce fan-generated sound) are available on request.

Dimensions and weights

FPAC-1, FPMC-1

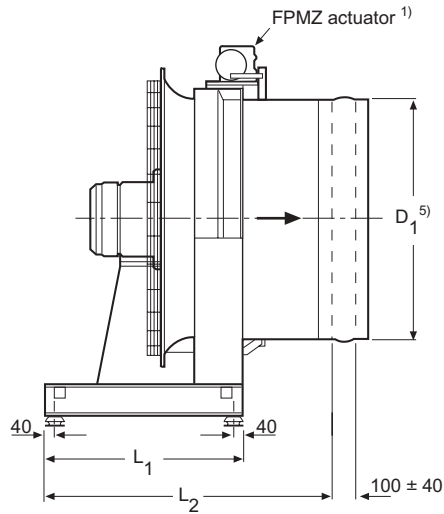

FPAC-7, FPMC-7

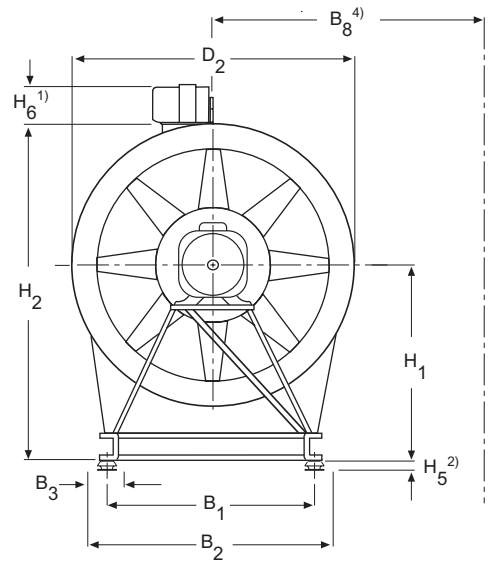
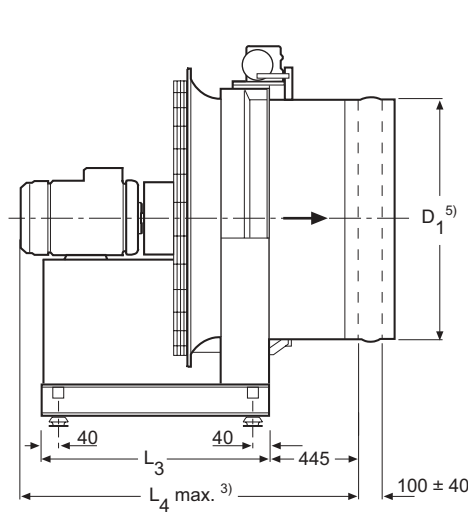

Size	Motor size <sup>3)</sup>	B1	B2	B3	B8	D1 <sup>5)</sup>	D2	H1	H2		L1	L2	L3	L4	Weight, kg, excl motor	
									FPAC	FPMC					Arr. 1	Arr. 7
080	132	785	840	60	800	800 - 820	1075	710	1240	1300	740	1185	1000	1530	250	290
	1105												1680	255	300	
	1155												1750	260	320	
090	132	835	895	65	900	900 - 920	1175	760	1340	1400	780	1225	1100	1530	270	330
	1105												1680	275	340	
	1155												1750	280	350	
	1190												1770	285	360	
100	160	925	985	65	1000	1000 - 1020	1275	810	1440	1500	805	1250	1105	1680	310	360
	1155												1750	320	370	
	1190												1770	330	390	
	1250												1860	340	410	
112	160	1010	1070	65	1100	1120 - 1140	1395	875	1565	1620	970	1415	1105	1680	350	390
	1155												1750	360	410	
	1190												1770	370	430	
125	180	1135	1200	70	1200	1250 - 1270	1625	1030	1835	1845	1085	1530	1155	1750	420	520
	1190												1770	430	540	
	1250												1860	440	560	
140	200	1210	1275	70	1400	1400 - 1420	1775	1110	1990	2000	1100 <sup>6)</sup>	1545 <sup>6)</sup>	1190	1770	525 <sup>6)</sup>	600
	1250												1860	630		
	1320												2025	680		
140	280	1210	1275	70	1400	1400 - 1420	1775	1110	1990	2000	1400 <sup>6)</sup>	1845 <sup>6)</sup>	1420	2105	605 <sup>6)</sup>	750
	315												1585	830		
	355												1715	860		
160	225	1305	1375	75	1600	1600 - 1620	1975	1195	2175	2185	1120 <sup>6)</sup>	1565 <sup>6)</sup>	1250	1860	635 <sup>6)</sup>	680
	1320												2025	740		
	1420												2105			
160	280	1305	1375	75	1600	1600 - 1620	1975	1195	2175	2185	1600 <sup>6)</sup>	2045 <sup>6)</sup>	1420	2105	650 <sup>6)</sup>	800
	315												1585	880		
	355												1715	940		
180	225	1440	1520	80	1600	1800 - 1820	2175	1300	2380	2390	1260 <sup>6)</sup>	1705 <sup>6)</sup>	1250	1860	650 <sup>6)</sup>	790
	1320												2025	850		
	1420												2105			
180	280	1440	1520	80	1600	1800 - 1820	2175	1300	2380	2390	1800 <sup>6)</sup>	2245 <sup>6)</sup>	1420	2105	710 <sup>6)</sup>	900
	1585												2285	960		
	1715												2510	1040		

<sup>1)</sup> Applies only to the FPMC

Actuator	H6 <sup>1)</sup>
FPMZ-07	250
FPMZ-09	300
FPMZ-13	150

<sup>2)</sup> For dimension H5, see the table entitled "Anti-vibration mountings" on page 32.

<sup>3)</sup> Applies to squirrel-cage induction motors from ABB Motors.

<sup>4)</sup> Recommended service space.

<sup>5)</sup> Dimensions D1 are the outside diameters of the ducts that may be connected.

<sup>6)</sup> For FPAC-fans, arr. 1, size 140 - 180 available upon request. Figures and weights are approximative.



Dimensions and weights

FPAC-1, FPMC-1

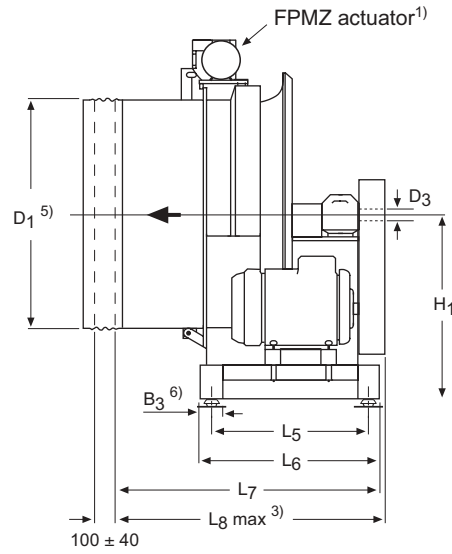
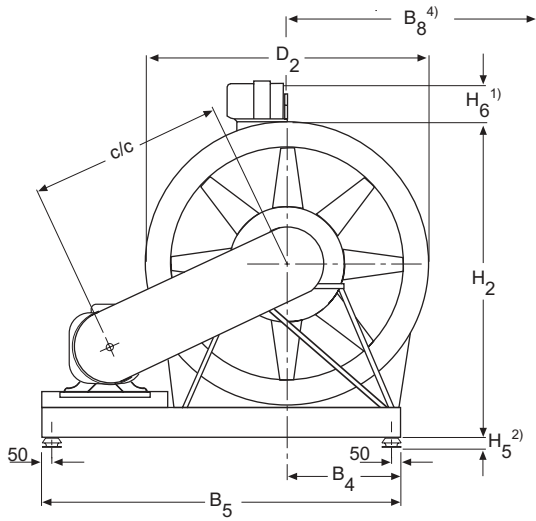

Actuator	H6 <sup>1)</sup>
FPMZ-07	250
FPMZ-09	300
FPMZ-13	150

Size	Motor size <sup>3)</sup>	B <sub>3</sub>	B <sub>4</sub>	B <sub>5</sub>	B <sub>8</sub>	D <sub>1</sub> <sup>5)</sup>	D <sub>2</sub>	D <sub>3</sub>	H <sub>1</sub>	H <sub>2</sub> FPAC	H <sub>2</sub> FPMC	L <sub>5</sub>	L <sub>6</sub>	L <sub>7</sub>	L <sub>8</sub>	c/c	Weight, kg excl. motor
080	160	60	520	1645	800	800 - 820	1075	55	740	1270	1330	645	745	1150	1310	760 - 875	445
	180			1645										770 - 885		450	
	200			1760										780 - 920		450	
	225			1805										795 - 935		460	
	250			1870										795 - 940		460	
090	180	65	550	1750	900	900 - 920	1175	55	770	1350	1410	705	805	1215	1380	810 - 925	515
	200			1815										820 - 960		520	
	225			1860										830 - 975		530	
	250			1925										835 - 980		540	
	280			1975										855 - 995		545	
100	200	65	590	1905	1000	1000 - 1020	1275	75	820	1450	1510	760	860	1270	1475	880 - 1020	585
	225			1950										895 - 1030		605	
	250			2015										895 - 1035		605	
	280			2065										910 - 1055		635	
	225	65	635	2035	1100	1120 - 1140	1395	75	885	1575	1630	845	945	1355	1555	960 - 1095	660
	250			2100					960 - 1095					660			
	280			2150					975 - 1115					690			
	315			2250					995 - 1140					690			

<sup>1)</sup> Applies only to the FPMC.

<sup>2)</sup> For dimension H<sub>5</sub>, see the table entitled "Anti-vibration mountings" on page 32.

<sup>3)</sup> Applies to squirrel-cage induction motors from ABB Motors.

<sup>4)</sup> Recommended service space.

<sup>5)</sup> Dimensions D<sub>1</sub> are the outside diameters of the ducts that may be connected.

Dimensions and weights

FPAC-6, FPMC-6

Horizontal

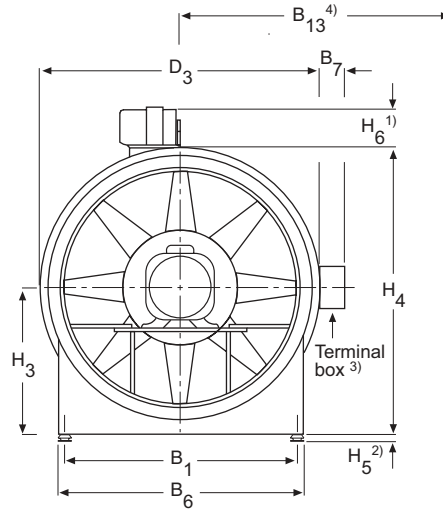
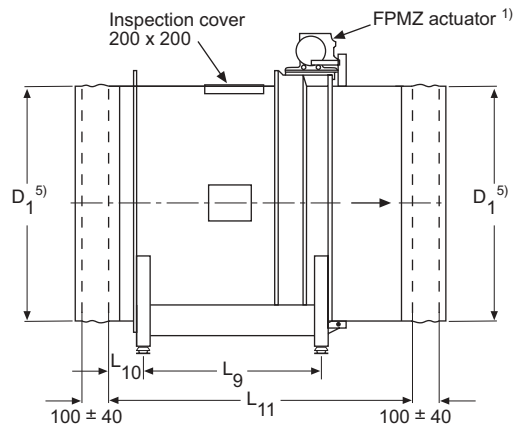

Actuator	H6 <sup>1)</sup>
FPMZ-07	250
FPMZ-09	300
FPMZ-13	150

<sup>1)</sup> Applies only to the FPMC.

<sup>2)</sup> For dimension H5, see the table entitled "Anti-vibration mountings" on page 32.

<sup>3)</sup> Sizes 112 - 180.

<sup>4)</sup> Recommended service space.

<sup>5)</sup> Dimensions D1 are the outside diameters of the ducts that may be connected.

FPAC-6

Vertical

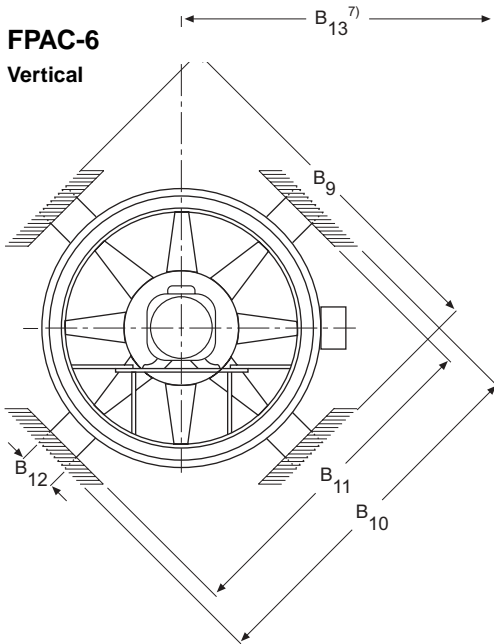

Size	B1	B6	B7	B9	B10	B11	B12	B13	D1	D3	H3
080	700	800	45	1250	1150	1030	150	800	800 - 820	915	520
090	800	900	65	1350	1250	1130	150	900	900 - 920	1015	570
100	860	960	65	1460	1340	1230	175	1000	1000 - 1020	1115	620
112	1010	1110	265	1640	1520	1400	175	1100	1120 - 1140	1290	700
125	1135	1235	265	1910	1750	1560	200	1200	1250 - 1270	1420	765
140	1210	1310	310	2160	2000	1800	200	1400	1400 - 1420	1575	850
160	1305	1405	310	2360	2200	2000	200	1600	1600 - 1620	1775	950
180	1440	1540	310	2560	2400	2200	250	1600	1800 - 1820	1975	1050

Size	H4		L9	L10	L11	L12	L13	Weight, kg, excl. motor	
	FPAZ	FPMC						Horizontal	Vertical
080	980	1105	720	85	1285	890	770	230	275
090	1080	1205	750	85	1315	900	770	260	300
100	1180	1300	810	85	1375	920	770	290	340 - 400
112	1345	1440	960	95	1550	925	815	370 - 450	390 - 470
125	1475	1570	950	105	1570	980	850	500 - 590	540 - 620
140	1640	1730	1055	120	1710	1070	950	600 - 690	640 - 740
160	1840	1930	1055	120	1710	1070	950	760 - 850	790 - 880
180	2040	2135	1055	120	1710	1080	930	860 - 950	910 - 990

Upward air discharge

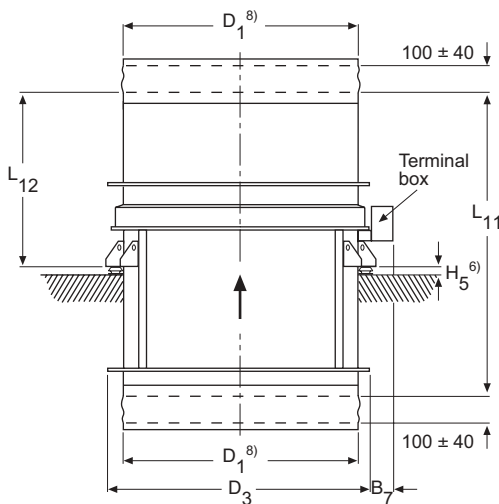

Downward air discharge

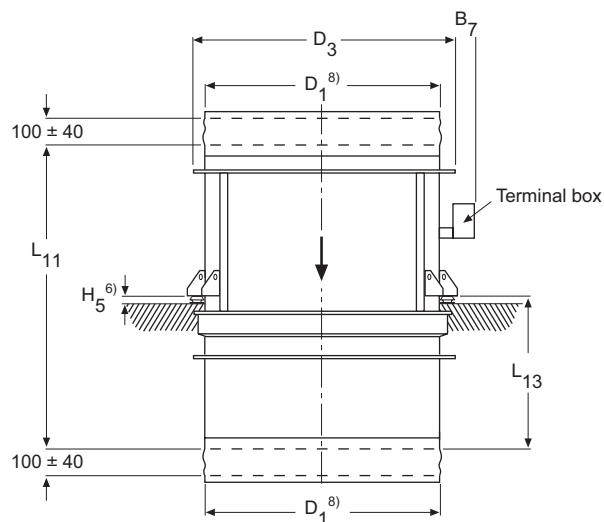

<sup>6)</sup> For dimension H5, see the table entitled "Anti-vibration mountings" on page 32.

<sup>7)</sup> Recommended service space.

<sup>8)</sup> Dimensions D1 are the outside diameters of the ducts that may be connected.

Dimensions and weights

Accessories, CD design

FP(A,M)C fan with FP(A,M)Z-01 guide vane diffuser

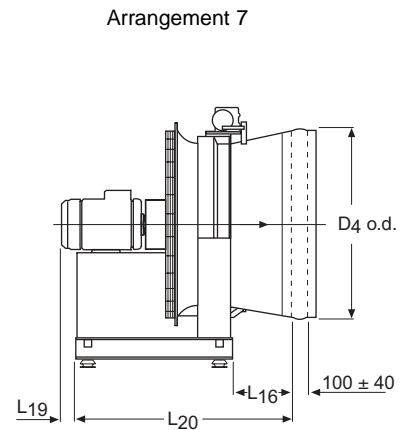
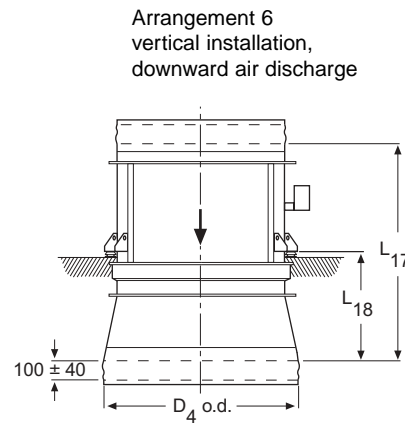
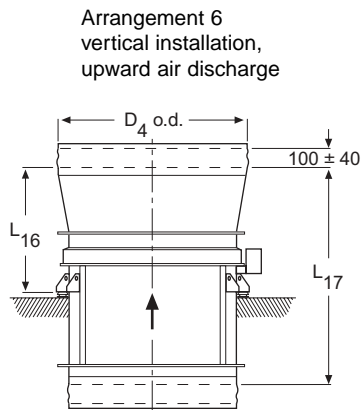
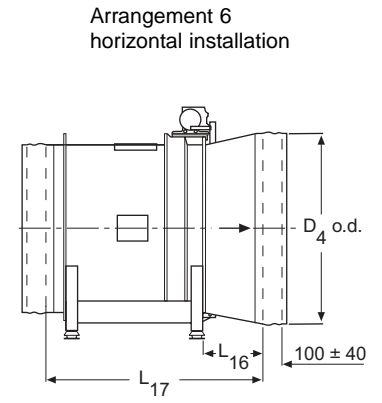
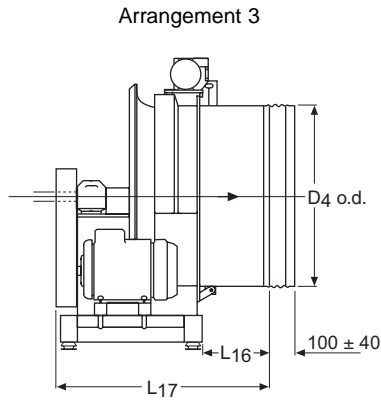
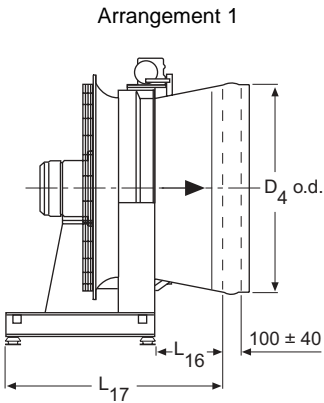

Size	D4 o.d. <sup>1)</sup>	Arrangement 1		Arrangement 3		Arrangement 6 horizontal installation		Arrangement 6 horizontal installation upward air discharge		Arrangement 6 vertical installation downward air discharge		Arrangement 7 L16
		L16	L17	L16	L17	L16	L17	L16	L17	L17	L18	
080	900 - 920	545	1285	545 <sup>2)</sup>	1410 <sup>2)</sup>	545	1385	990	1385	1385	870	545
090	1000 - 1020	545	1325	545	1480	545	1415	1000	1415	1415	870	545
100	1120 - 1140	545	1350	545	1575	545	1475	1020	1475	1475	870	545
112	1250 - 1270	545	1515	545	1655	550	1650	1025	1650	1650	915	545
125	1400 - 1420	545	1630	-	-	560	1670	1080	1670	1670	950	545
140	1600 - 1620	745 <sup>5)</sup>	1845 <sup>5), 6)</sup>	-	-	745	2010	1370	2010	2010	1120	745
160	1800 - 1820	745 <sup>5)</sup>	1865 <sup>5), 7)</sup>	-	-	745	2010	1370	2010	2010	1250	745
180	2000 - 2020	745 <sup>5)</sup>	2005 <sup>5), 8)</sup>	-	-	745	2010	1380	2010	2010	1230	745

Motor size	L19 <sup>3)</sup>	L20
132	85	1545
160	130	1650
180	150	1700
200	135	1735 <sup>4)</sup>
225	165	1795 <sup>4)</sup>
250	260	1865 <sup>4)</sup>
280	240	1965 <sup>4)</sup>
315	255	2130 <sup>4)</sup>
355	350	2460

- <sup>1)</sup> The outer diameter of the duct connected must be within the dimension range specified under D4.
- <sup>2)</sup> One motor size 250, dimension L16, L17 = 530 mm and 1380 respectively.
- <sup>3)</sup> Applicable to ABB squirrel-cage induction motors.
- <sup>4)</sup> On fan sizes 140 and larger, this dimension must be increased by 200 mm.
- <sup>5)</sup> For FPAC-fans, arr. 1, size 140 - 180 available upon request. Figures are approximative.
- <sup>6)</sup> On motor sizes 280 and larger - 2145 mm.
- <sup>7)</sup> On motor sizes 280 and larger - 2345 mm.
- <sup>8)</sup> On motor sizes 280 and larger - 2545 mm.

Note! For the height of the anti-vibration mountings, see page 32  
For other dimensions, see pages 24, 25 and 26

Dimensions and weights

FPAC - Control equipment

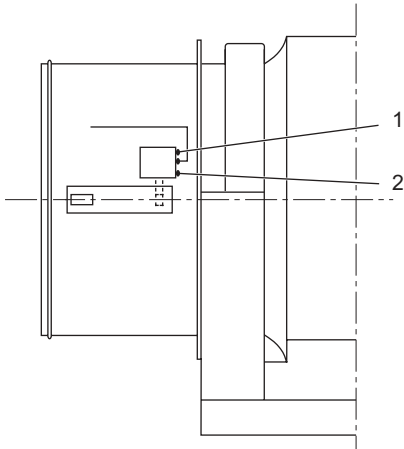

Controlling the blade angle

FPAC - Required control pressure, kPa

Arrangements 1, 6 and 7			Arrangement 3
n = 980 r/min No. of blades d = 8	n = 1470 r/min No. of blades d = 8   9		No. of blades d = 8
Note. The max. pressure for all arrangements is 550 kPa			
250	450	350	500

1. Control pressure connection. (6 mm o.d./4 mm i.d. plastic hose)
2. Signal pressure connection. (6 mm o.d./4 mm i.d. plastic hose)

FPMC - Control equipment

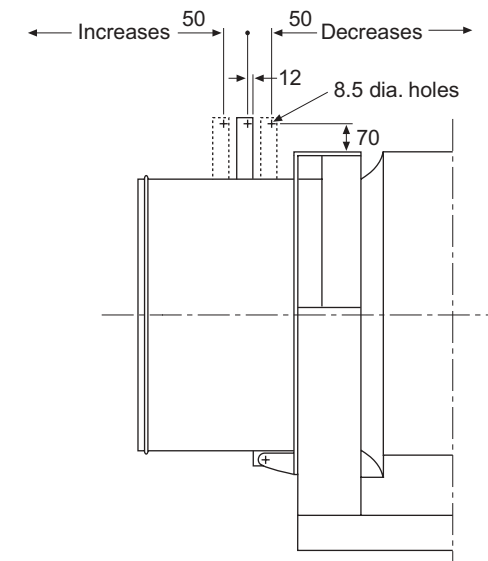

FPMC - Required operating force, N

Size - hub	Arrangements 1, 6 and 7		Arrangement 3
	n = 980 r/min No. of blades d = 8	n = 1470 r/min No. of blades d = 8	n = max. r/min as per table on p. 34. No. of blades d = 8
bbb-c			
080-5	120	300	680
090-5	130	320	-
100-5	140	330	-
112-5	150	390	-
125-5	160	420	-
090-6	130	330	680
100-6	140	360	730
112-6	150	380	700
125-6	170	450	-
140-6	190	480	-
160-6	210	530	-

FPMC - Actuator

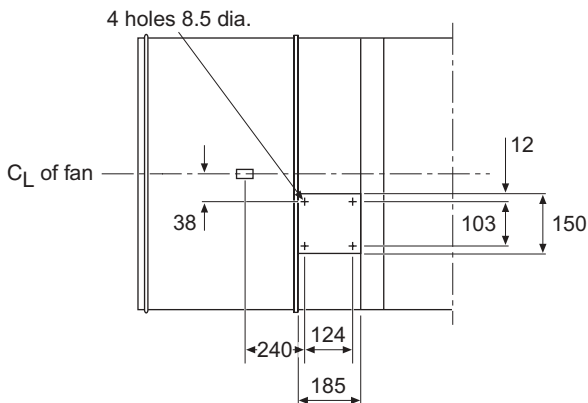

Code	Max. operating force	Electric data	Type
FPMZ-07-1	500 N	220-240 V AC, 50 Hz Power consumption: 17 W 120 sec. actuating period/180°	Sauter A44 W1-F001
FPMZ-07-2		Built-in positioner Supply voltage: 24 V AC Control signal: 2-10 V DC Power consumption: 20 W 120 sec. actuating period/180°	Sauter A44 W1S-F001
FPMZ-09-1	1000 N	220-240 V AC, 50/60 Hz Power consumption: 20 W 60 sec. actuating period 180°	Bernard OAP
FPMZ-09-2		Equipped with a separate positioner which is to be mounted adjacent to the fan. The positioner is supplied, connected to the actuator by 3 m wire. Supply voltage: 230 V, 50/60 Hz Control signal : 4-20 mA DC	
FPMZ-13-1	250N	220-240 V AC, 50/60 Hz Power consumption: 7 W 110 sec. actuating period/180°	Sauter AR30 W12S-F002
FPMZ-13-2		Built-in positioner Supply voltage: 24 V AC Control signal: 2-10 V DC Power consumption: 12 W 110 sec. actuating period/180°	Sauter AR30 W12S-F002

Dimensions and weights, accessories

FPAZ-04 Air distributor

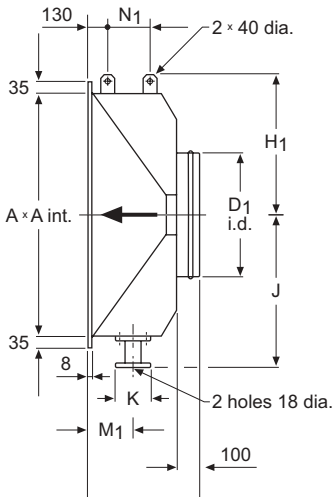

FPAZ-04, FPAZ-05

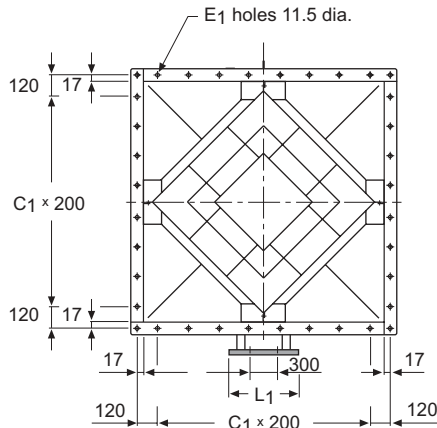

Size 080 - 100

FPAZ-04, FPAZ-05

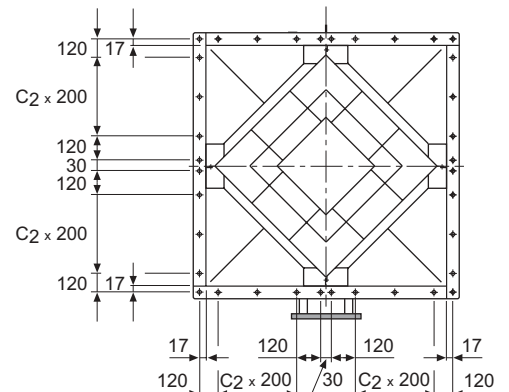

Size 112 - 180

FPAZ-05 Air distributor

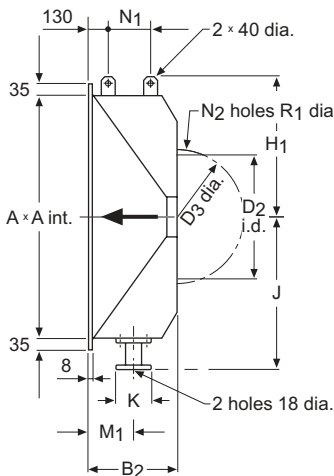

Size	A	B1	B2	C1	C2	D1 i.d.	D2 i.d.	D3	E1	H1	J	K	L1	M1	N1	N2	R1	Weight, kg	
																		FPAZ-04	FPAZ-05
080	1600	660	560	7	-	814	1005	1070	36	933	1003	220	500	275	245	16	M12	210	215
090	1800	730	630	8	-	914	1125	1190	40	1033	1103	220	500	275	265	20	M12	240	245
100	2000	800	700	9	-	1016	1255	1320	44	1133	1203	220	500	275	335	20	M12	285	295
112	2470	884	785	-	5	1136	1405	1470	60	1368	1438	280	500	365	390	20	M12	370	420
125	2470	975	875	-	5	1268	1605	1680	60	1368	1438	280	500	365	480	24	M16	395	440
140	2870	1100	1000	-	6	1418	1805	1880	68	1568	1788	300	600	555	555	24	M16	550	570
160	3270	1100	1000	-	7	1620	2005	2080	76	1768	1988	300	600	555	555	24	M16	625	640
180	3670	1100	1000	-	8	1820	2245	2320	84	1968	2188	300	600	555	555	28	M16	700	715

FPAZ-06 transition piece

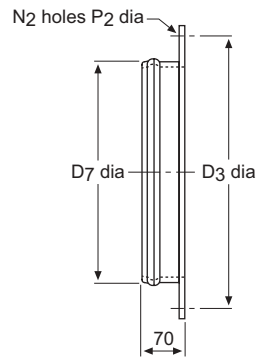

FPAZ-02 diffuser

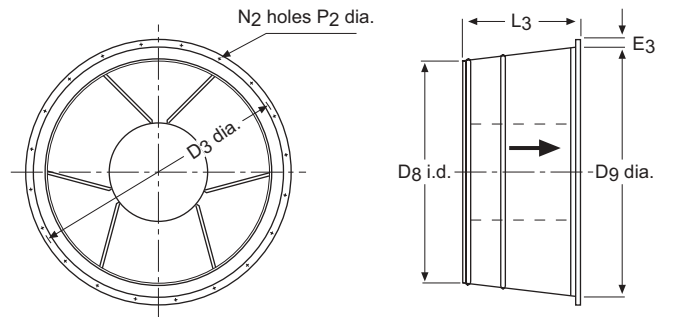

FPAZ-21 inlet with protective grille for arrangement 6

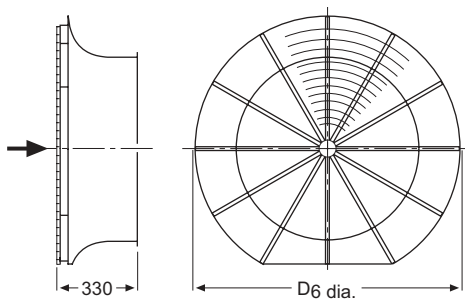

FPAZ-03 diffuser

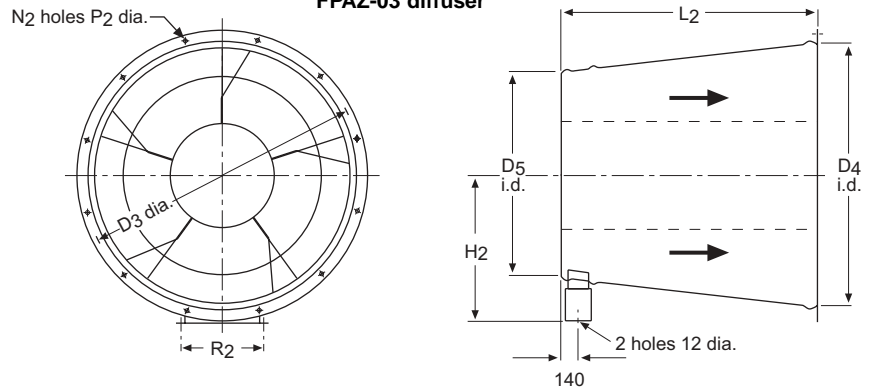

Size	D3	D4	D5	D6	D7	D8	D9	E3	H2		H3	L2	L3	N2	P2	R2	Weight, kg			
									min.	max.							FPAZ-02	FPAZ-03	FPAZ-06	FPAZ-21
080	1070	1005	814	1150	915	913	1006	50	675	785	493	1035	450	16	15		40	65	13	20
090	1190	1125	914	1250	1015	1013	1126	50	755	865	543	1140	550	20	15	454	50	70	16	22
100	1320	1255	1016	1350	1135	1134	1256	50	775	885	593	1300	600	20	15		60	87	19	25
112	1470	1405	1136	1470	1265	1263	1410	50	800	950	653	1320	650	20	15		65	105	22	28
125	1680	1605	1268	1600	1420	1418	1610	60	955	1105	720	1660	700	24	19	454	85	140	30	32
140	1880	1805	1418	1750	1620	1618	1810	60	1035	1185	845	1900	700	24	19	554	100	170	34	36
160	2080	2005	1620	1950	1820	1818	2010	60	1120	1270	945	1900	700	24	19	554	110	185	37	42
180	2320	2245	1820	2150	2020	2018	2238	70	1220	1370	1045	2000	800	28	19	554	145	200	46	47

## Dimensions and weights, accessories

### FPAZ-24 Silencer

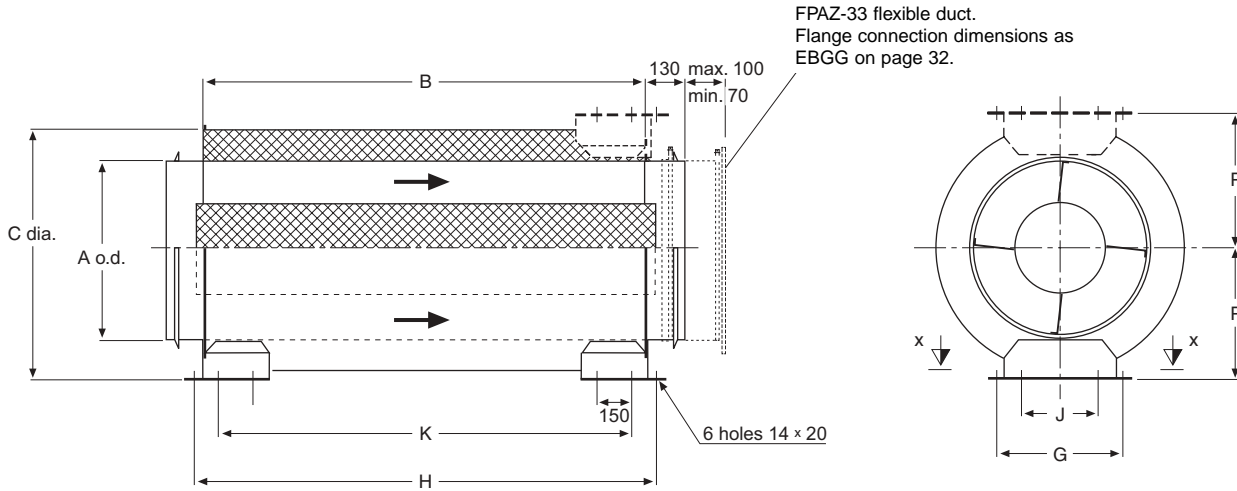

Size	A	B	C	G	H	J	K	P	Weight, kg			
									Q1 c = 0 <sup>1)</sup>	Q2 c = 5 <sup>1)</sup>	Q3 c = 6 <sup>1)</sup>	Q4 c = 8 <sup>1)</sup>
080	800	1223	1028	540	1270	400	1130	530	83	109	-	-
090	900	1223	1128	540	1270	400	1130	586	92	118	127	-
100	1000	1223	1228	640	1270	500	1130	630	104	131	137	-
112	1120	1800	1348	640	1845	500	1705	696	147	185	193	208
125	1250	1800	1478	765	1845	625	1705	760	164	203	212	226
140	1400	1800	1328	765	1845	625	1705	845	180	-	228	243

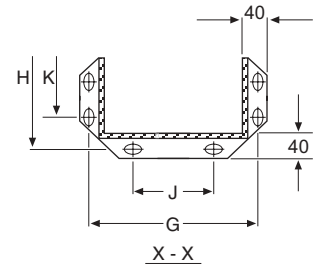

<sup>1)</sup> c refers to the central core diameter.  
See the ordering key for the FPAZ-24 on page 21

Q1, Q2, Q3, Q4 = Total weight

For particulars of other cylindrical and baffle type silencers - get in touch with your nearest Fläkt Woods representative

### Diffuser FPAZ-25 with sound attenuation

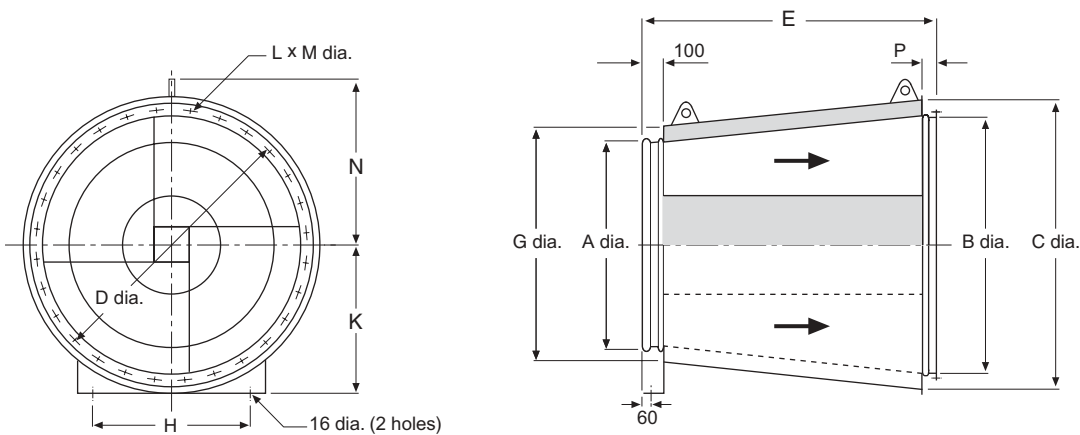

Size	A	B	C	D	E	G	H	P		L	M	N	P	Weight kg
								min.	max.					
080	814	1008	1215	1070	1195	1020	400	675	785	16	15	665	60	210
090	914	1128	1335	1190	1300	1120	400	755	865	20	15	725	60	265
100	1016	1258	1465	1320	1460	1225	400	775	885	20	15	790	60	310
112	1136	1412	1615	1470	1480	1345	400	800	950	20	15	865	60	360
125	1268	1612	1815	1680	1820	1475	480	955	1105	24	19	965	60	505
140	1418	1812	2015	1880	2060	1625	480	1035	1185	24	19	1065	60	605
160	1620	2012	2215	2080	2060	1830	480	1120	1270	24	19	1165	60	665
180	1820	2240	2455	2320	2180	2030	480	1220	1370	28	19	1285	80	750

**Acoustic data for FPAZ-24 silencer**

The silencer can be delivered with or without central core (see the ordering key on page 21). The central core is specially suited to each hub diameter. Table 1 below can be used as a guide for selecting a silencer.

**Table 1**

		Without central core	With central core
1 silencer	Attenuation Pressure drop	about 10 dB(A) None	about 15 dB(A) Low
2 silencers installed in line	Attenuation Pressure drop	about 15 dB(A) None	about 20 dB(A) Moderate

The particulars specified are applicable to a silencer fitted to the fan outlet. When fitted to the fan inlet, the attenuation will increase by 1 - 2 dB(A). The change per individual octave band will be somewhat greater.

**Table 2. Acoustic data for an FPAZ-24 silencer**

Size <sup>1)</sup> bbb-c	Attenuation, dB Octave band, mid-frequency, Hz								k <sup>d</sup> <sub>dBA</sub> dB(A)	Pressure constant z
	63	125	250	500	1000	2000	4000	8000		
080-0	2	3	10	14	12	11	9	8	11	0
080-5	2	3	10	15	22	25	16	12	17	0.30
090-0	1	2	8	13	11	10	9	8	10	0
090-5	1	2	8	15	17	18	12	10	15	0.19
090-6	2	2	9	16	20	21	14	11	16	0.42
100-0	0	2	7	12	10	9	9	9	10	0
100-5	1	2	7	14	16	12	10	9	14	0.14
100-6	1	2	8	16	18	15	11	9	15	0.25
112-0	0	3	9	13	11	10	10	10	11	0
112-5	1	3	9	15	16	14	12	10	15	0.15
112-6	1	3	9	16	17	16	12	11	15	0.24
112-8	1	3	11	17	18	18	12	12	16	0.65
125-0	0	2	9	11	10	9	9	9	10	0
125-5	0	2	9	15	14	12	11	11	13	0.12
125-6	0	3	9	15	15	13	11	11	14	0.17
125-8	0	3	10	15	16	15	12	11	15	0.35
140-0	0	2	9	10	10	9	9	9	9	0
140-6	0	3	9	16	13	12	10	10	12	0.12
140-8	0	3	9	15	14	12	11	10	13	0.21

**Table 3. Acoustic data for two FPAZ-24 silencers installed in line**

Size <sup>1)</sup> bbb-c	Attenuation, dB Octave band, mid-frequency, Hz								k <sup>d</sup> <sub>dBA</sub> dB(A)	Pressure constant z
	63	125	250	500	1000	2000	4000	8000		
080-0	2	4	15	19	18	14	12	10	16	0
080-5	3	4	15	19	34	30	25	22	21	0.60
090-0	2	4	12	18	16	13	12	11	14	0
090-5	3	4	12	18	26	24	20	17	20	0.38
090-6	4	4	13	18	27	27	23	18	20	0.84
100-0	1	3	10	17	14	12	12	11	14	0
100-5	2	3	10	17	22	19	16	14	19	0.28
100-6	2	4	11	17	24	22	18	15	19	0.50
112-0	2	4	13	17	16	14	14	14	15	0
112-5	2	4	14	18	23	21	19	17	21	0.30
112-6	2	5	15	19	24	23	19	19	21	0.48
112-8	3	7	17	21	23	25	19	19	21	1.30
125-0	1	4	13	15	14	13	13	14	13	0
125-5	1	5	14	19	20	19	17	17	19	0.24
125-6	1	5	14	19	20	19	17	17	19	0.34
125-8	1	5	16	19	20	21	18	17	19	0.70
140-0	1	4	12	14	13	12	12	12	12	0
140-6	0	4	14	19	18	17	15	15	17	0.24
140-8	0	4	15	18	19	18	16	14	17	0.42

<sup>1)</sup> bbb = size of silencer  
 c = 0 = without central core  
 c = 5, 6, 8 = with central core for hub diameter 5, 6, and 8 resp.

The pressure drop can be calculated from the formula  $\Delta p = z \times p_d$ . The value z can be obtained from tables 2 and 3.

**Acoustic data for FPAZ-25 diffuser**

FPAC FPMC Size bbb-c	Attenuation, dB Octave band, mid-frequency, Hz								k <sup>d</sup> <sub>dBA</sub> dB(A)
	63	125	250	500	1000	2000	4000	8000	
080-5	1	3	6	10	14	19	13	8	12
090-5	2	3	6	9	14	15	10	6	11
090-6	2	3	7	11	16	22	16	10	13
100-5	2	4	7	10	14	12	8	4	11
100-6	2	4	7	11	16	18	12	7	13
112-5	2	4	6	9	12	9	5	3	10
112-6	2	4	7	10	14	12	8	4	11
112-8	2	4	7	12	17	20	13	8	14
125-5	2	5	7	11	12	8	5	3	10
125-6	2	5	8	12	15	11	7	4	12
125-8	2	5	9	13	18	16	10	6	14
140-6	3	5	8	12	13	9	5	3	10
140-8	3	5	9	13	17	12	8	4	13
160-6	3	5	8	10	10	6	4	2	10
160-8	3	5	8	12	12	8	5	2	10
180-6	3	5	7	10	8	5	3	1	7
180-8	3	5	8	11	9	6	3	2	8

**Worked example**

**Given**

Determine the sound power levels to the inlet and to the outlet duct for an FPAC-7-125-6-8 fan running at a speed of 1470 r/min. Operating point of the fan: total pressure rise of 1388 Pa, flow of 30 m<sup>3</sup>/s and air density of 1.2 kg/m<sup>3</sup>. Also calculate the sound power level to the outlet duct if an FPAZ-25 diffuser with sound attenuation is installed.

**Solution**

	Octave band, mid-frequency, Hz								Total dB(A)
	63	125	250	500	1000	2000	4000	8000	
L <sub>wt</sub> [dB(A)] <sup>1)</sup>	115	115	115	115	115	115	115	115	-
k <sub>okb</sub> (dB) <sup>2)</sup>	-16	-14	-7	-6	-3	-7	-12	-14	-
L <sub>wb</sub> (dB) <sup>3)</sup>	99	101	108	109	112	108	103	101	115
k <sub>oka</sub> (dB) <sup>4)</sup>	-13	-14	-7	-6	-3	-7	-13	-17	-
L <sub>wa</sub> (dB) <sup>5)</sup>	102	101	108	109	112	108	102	98	115
Acoustic diffuser <sup>6)</sup> FPAZ-25-125-6	-2	-5	-8	-12	-15	-11	-7	-4	-
L <sub>wa</sub> down-stream <sup>7)</sup> of acoustic diffuser	100	96	100	97	97	97	95	94	103 <sup>8)</sup>

- L<sub>wt</sub> = 115 dB(A) in accordance with the example on page 8.
- k<sub>okb</sub> can be read from the table on page 23.
- L<sub>wb</sub> = L<sub>wt</sub> + k<sub>okb</sub>, i.e. line 1 + line 2.
- k<sub>oka</sub> can be read from the table on page 23.
- L<sub>wa</sub> = L<sub>wb</sub> + k<sub>oka</sub>, i.e. line 1 + line 4.
- The attenuation data can be read from the table above.
- Line 5 + line 6
- The total sound power level downstream of the acoustic diffuser is  
 $L_{wt} - k^d_{dBA} = 115 - 12 = 103$ . k<sup>d</sup><sub>dBA</sub> can be read from the table above

**Silencer and sound-attenuating diffuser**

The sound attenuating properties of sound-attenuating accessories and the pressure drops across them are measured directly as a reduction in sound power level and total pressure respectively when the accessory is mounted at the fan outlet. (A usual but inferior alternative is to employ a loudspeaker instead of a fan as the sound source). The performance of a sound-attenuated fan has been determined by AMCA 210 - 85 and AMCA 300 - 85 measurement methods.

**Dimensions and weights**

**Accessories**

**EBGA/EBGG flanges and EBGV grouting-in frame**

Circular, geometric size series.  
The flanges are designed according to ISO 6580, which is equivalent to EUROVENT 1/2.  
For particulars of finish, see the ordering key.

**EBGA** - Flat bar flange, steel

**EBGG** - Angle flange, steel

**EBGV** - Grouting-in frame, steel (with dome nuts)

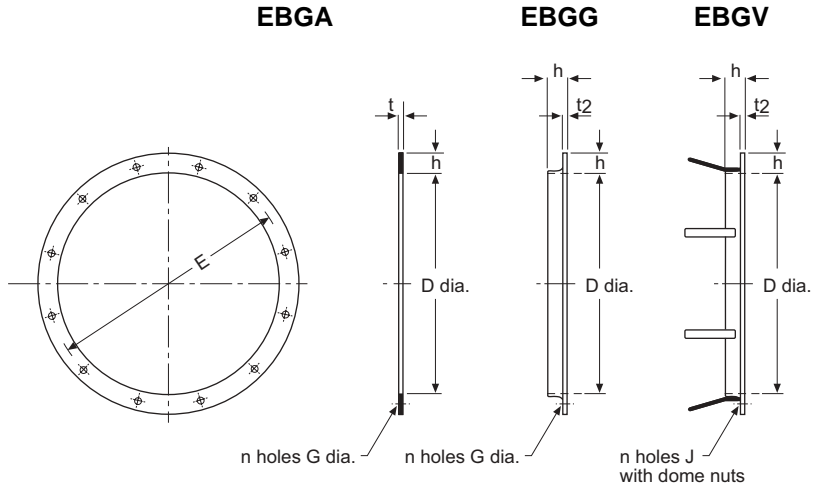

Size	EBGA-a-bbb EBGG-a-bbb EBGV-a-bbb	D	E	G	J	h	n	t1	t2	Weight, kg	
										EBGA	EBGG EBGV
035		359	395	10	M8	35	8	6	6	2.1	3.9
040		406	450	12	M10	40	8	6	5	2.6	4.2
045		456	500	12	M10	40	8	6	5	2.9	4.7
050		506	560	12	M10	50	12	6	6	3.5	7.8
056		566	620	12	M10	50	12	6	6	4.6	9.0
063		636	690	12	M10	50	12	6	6	5.1	9.7
071		716	770	12	M10	50	16	6	6	5.7	10.9
080		808	860	12	M10	50	16	6	6	6.3	12.1
090		908	970	15	M12	60	16	6	6	8.6	16.4
100		1008	1070	15	M12	60	16	6	6	9.5	18.1
112		1128	1190	15	M12	60	20	6	6	10.5	20.1
125		1258	1320	15	M12	60	20	6	6	11.7	22.3
140		1412	1470	15	M12	60	20	6	6	13.1	24.9
160		1612	1680	19	M16	60	24	8	6	14.9	28.3
180		1812	1880	19	M16	60	24	8	6	16.6	31.7
200		2012	2080	19	M16	60	24	8	6	18.4	35.1
224		2240	2320	19	M16	80	28	10	8	45.2	67.7

**Anti-vibration mountings**

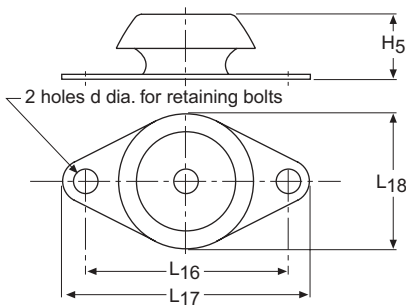

Anti-vibration mountings	L16	L17	L18	d	H5 when loaded
A	110	128	82	11	30
B	144	172	110	13.5	37
C	182	212	152	13.5	47

**Anti-vibration mountings for arr. 1**

Size	Motor	Anti-vibration mountings
080	All	A
090	132S - 160L	A
	180M - 200L	B
100	All	B
112	All	B
125	180M - 225M	B
	250m - 315S	C

**Anti-vibration mountings for arr. 6, horizontal installation**

Size	Motor	Anti-vibration mountings
080	All	A
090	All	A
100	160M - 200L	A
	225S - 225M	B
112	160M - 160L	A
	180M - 280M	B
125	All	B
140	180M - 280M	B
	315S - 315L	C
160	225S - 225M	B
	250M - 355S	C
180	All	C

**Anti-vibration mountings for arr. 7**

Size	Motor	Anti-vibration mountings
080	All	A
090	132S - 180L	A
	200L	B
100	All	B
112	All	B
125	All	B
140	200L - 280M	B
	315S - 355S	C
160	All	C
180	All	C

**Anti-vibration mountings for arr. 6, vertical installation**

Size	Motor	Anti-vibration mountings
080	All	A
090	All	A
100	160M - 200L	A
	200L - 225M	B
112	All	B
125	All	B
140	200L - 280M	B
	315S - 315L	C
160	225S - 225M	B
	250M - 355S	C
180	All	C

**Anti-vibration mountings for arr. 3**

Size	Motor	Anti-vibration mountings
080	All	B
090	All	B
100	200L - 250M	B
	280S - 280M	C
112	225S - 250M	B
	250M - 315S	C



Conversion factors, qualities and units, formulae

Volume

1 m <sup>3</sup>	= 35.3 ft <sup>3</sup>	1 ft <sup>3</sup>	= 0.0283 m <sup>3</sup>
1 cm <sup>3</sup>	= 0.0610 in <sup>3</sup>	1 in <sup>3</sup>	= 16.4 cm <sup>3</sup>
1 l	= 0.220 gallon (UK)	1 gallon (UK)	= 4.55 l
1 l	= 0.264 gallon (US)	1 gallon (US)	= 3.79 l

Flow

1 m <sup>3</sup> /h	= 0.278 x 10 <sup>-3</sup> m <sup>3</sup> /s	1 m <sup>3</sup> /s	= 3600 m <sup>3</sup> /h
1 cfm	= 0.472 x 10 <sup>-3</sup> m <sup>3</sup> /s	1 m <sup>3</sup> /s	= 2120 m <sup>3</sup> /h

Mass

1 lb	= 0.454 kg	1 kg	= 2.2 lb
1 oz	= 28.3 g	1 g	= 0.0352 oz

Force

1 kg	= 9.81 N	1 N	= 0.102 kg
1 lbf	= 4.45 N	1 N	= 0.225 lbf

Pressure

1 mm vp	= 9.81 Pa	1 Pa	= 0.102 mm vp
1 kp/cm <sup>2</sup>	= 98.1 kPa	1 kPa	= 0.0102 kp/cm <sup>2</sup>
1 kp/cm <sup>2</sup>	= 0.891 bar	1 bar	= 1.021 kp/cm <sup>2</sup>
1 atm	= 101.325 kPa	1 kPa	= 0.00987 atm
1 lbf/in <sup>2</sup>	= 6.89 kPa	1 kPa	= 0.145 lbf/in <sup>2</sup>

Energy

1 kpm	= 9.81 J	1 J	= 0.102 kpm
1 cal	= 4.19 J	1 J	= 0.239 cal
1 kWh	= 3.60 MJ	1 MJ	= 0.278 kWh

Power

1 hk	= 0.736 kW	1 kW	= 1.36 hk
1 hk (UK, US)	= 0.746 kW	1 kW	= 1.34 (UK, US)
1 kcal/h	= 1.16 W	1 W	= 0.860 kcal/h

Temperature

0°C	= 32°F = 273.15 K	0°F	= - 17.8°C = 255.4 K
K	= 0°C + 273.15	°F	= 1.8 (°F - 273.15) + 32
°C	= $\frac{5}{9} (\text{°F} - 32)$	°F	= $\frac{5}{9} (\text{°C} + 32)$

Temperature conversion

°F	°C	K
0	- 17.8	255.4
10	- 12.2	261.0
20	- 6.7	266.5
30	- 1.1	272.0
32	0	273.15
40	4.4	277.6
50	9.9	283.1
60	15.5	288.7
70	21.0	294.2
80	26.6	299.8
90	32.1	305.3
100	37.8	311.0

Sound pressure level and sound power level

The sound pressure level  $L_p = 10 \log \left( \frac{p}{p_0} \right)^2$  dB

where p = the actual sound pressure and  $p_0 = 2 \times 10^{-5}$  Pa.

The **sound pressure level**, however, is not an absolute measurement of the acoustic characteristics at a sound source, since the acoustic design of the premises influences the sound propagation. It is therefore in general easiest to specify the **sound power level** instead of the sound pressure level for a given sound source. Since the sound power level is not directly measurable, it must be calculated from a sound pressure level, which has been measured under known acoustic conditions. If no reverberation occurs (difficult to achieve indoors!), the sound pressure level will decrease 6 dB as the distance from the sound source is doubled.

Frequency weighting filters

An amplifier and various filters are used for measuring the composite sound. By this method, the dB-values measured are specified with the suffix (A), (B) or (C) depending on the type of filter used. Normally only dB(A) values are specified which best correspond to sound perceived by the human ear.

Torque

$$M = F \times r \quad M = \frac{9550 \times P}{n}$$

where M = torque in Nm  
 F = force in N  
 r = leverage (radius) in m  
 P = power in kW (motor)  
 n = speed, rpm

Definition of fan efficiency

$$\eta = \frac{P}{P_e} \times 100\%$$

where  $P_e$  is the power demand and P is the theoretical power from

$$P = \frac{q \times \Delta p_t}{1000} \text{ kW,}$$

where q is in m<sup>3</sup>/s and  $\Delta p_t$  in Pa.

Gas flow

The gas flow in the fan chart always refers to the actual flow at the fan inlet. If the required gas flow has been specified at a temperature and pressure which deviates from the temperature and pressure prevailing at the fan inlet, the flow at the fan inlet is determined from:

$$q = q_1 \times \frac{T}{T_1} \times \frac{P_{a1}}{P_a}$$

Where T<sub>1</sub> and P<sub>a1</sub> are the temperature and pressure that deviate from the temperature T, and pressure, P<sub>a</sub>, that prevail at the fan inlet.

The required gas flow = q<sub>1</sub>. The gas flow at the inlet = q.

Fan performance at a different speed

If the fan speed is changed but the installation is otherwise unaltered, the gas flow, pressure rise and power level will be affected as follows:

$$\frac{q_1}{q_2} = \frac{n_1}{n_2} \quad \frac{\Delta p_{t1}}{\Delta p_{t2}} = \left( \frac{n_1}{n_2} \right)^2 \quad \frac{P_1}{P_2} = \left( \frac{n_1}{n_2} \right)^3$$

Using the fan chart

Unless otherwise specified, the **total pressure rise**  $\Delta p_t$  and power demand P shown in the fan chart always apply to a gas density of 1.2 kg/m<sup>3</sup> at the fan inlet, and this corresponds to the density of air at 20°, a normal barometric pressure of 1013 mbar (760 mm Hg) and a relative humidity of 50%.

If the density  $\rho$  of the gas deviates from 1.2 kg/m<sup>3</sup>, the required total pressure rise  $\Delta p_t$  used in reading the chart must be corrected as follows:

$$\Delta p_{t\text{chart}} = \frac{1.2}{\rho} \times \Delta p_t$$

The fan speed and power demand  $P_{e\text{chart}}$  can then be read from the chart. Finally, the actual power demand is obtained from:

$$P_e = \frac{\rho}{1.2} \times P_{e\text{chart}}$$

The gas density  $\rho_0$  is often known at a temperature, T<sub>0</sub>, and a pressure, P<sub>a0</sub>, which differ from the temperature, T, and pressure, P<sub>a</sub>, at the fan inlet. The density at the fan inlet can be calculated from the formula:

$$\rho = \rho_0 \times \frac{T_0}{T} \times \frac{P_a}{P_{a0}}$$

**Electric motors**

This catalogue section deals with totally enclosed, footmounted, three-phase squirrel cage motors for 50 Hz.

The two-speed motors are adapted for driving fans.

Quotations for motors incorporating temperature sensors will be submitted on request.

APAL Single-speed motors

ARAL Two-speed motors, with speed ratio of 1:2 and one stator winding (Dahlander-coupled)

ATAL Two-speed motors, with speed ratio 1:1.5 and separate stator windings

**Determination of the starting time**

Whenever fans or fan drives are presented with a specific motor, this is rated for **direct on-line starting**. If a different motor is selected or if a star-delta start is employed, the starting time must be checked by calculation.

Use the following formulae to calculate the starting time for direct on-line and star-delta starting:

$$t = \frac{J \times n_f^2 \times 10^{-3}}{46 \left[ P \left( \frac{M_{max}}{M} + \frac{M_{st}}{M} \right) - P_f \right]}$$

**Star-delta starting**

$$t = \frac{J \times n_f^2 \times 10^{-3}}{46 \left[ P \left( \frac{1}{3} \times \frac{M_{max}}{M} + \frac{1}{4} \times \frac{M_{st}}{M} \right) - P_f \right]}$$

**Permissible starting time**

The maximum permissible starting times for an individual start with the motor in cold condition are tabulated below.

Motor size	Method of starting	Max. starting time, seconds for an individual start	
		Number of poles	
		4	6
132	Direct on-line starting	12	20
	Star-delta starting	36	60
160-225	Direct on-line starting	15	20
	Star-delta starting	45	60
250	Direct on-line starting	15	20
	Star-delta starting	45	60
280	Direct on-line starting	18	17
	Star-delta starting	54	51
315	Direct on-line starting	18	16
	Star-delta starting	54	48
355	Direct on-line starting	20	18
	Star-delta starting	60	54

In most cases, it must be possible to restart a motor immediately after it has stopped. A good rule is therefore to utilise only one-third of the starting time listed in the table.

**NOTE!**

A star-delta starter may be used for starting a motor, provided that the motor is delta-coupled. During the starting process, the motor is star-coupled, and the torque it develops is therefore reduced. Check that the torque curve of the motor is higher than the torque curve of the fan up to 90% of the synchronous speed. If no torque curves are available for the motor, the following formula can be used with adequate accuracy for determining the minimum motor rating.

$$P_{Y/D} = \frac{2.6}{M_{max}} \times P_f \times M$$

If star-delta starting is employed, the starter should be set to the star setting for a period of time corresponding to the starting time calculated as described above, and should then be switched over to the delta setting.

**Symbols used**

- P = rated output of the motor ..... kW
- P<sub>f</sub><sup>1)</sup> = fan power demand at rated speed (incl. belt-drive losses if the fan is belt-driven ..... kW
- P<sub>Y/D</sub> = Minimum motor rating at which star-delta starting is possible ..... kW
- $\frac{M_{st}}{M}$  = ratio of motor starting torque to normal torque
- $\frac{M_{max}}{M}$  = ratio of max. motor torque to normal torque
- n<sub>f</sub> = rated speed of fan ..... r/min
- J = moment of inertia of the system, referred to the fan shaft<sup>2)</sup> ..... kg m<sup>2</sup>
- t = starting time ..... s

1) Also specified as P<sub>M</sub> in other catalogue sections.

2) The moment of inertia of the fan impeller is specified in the appropriate fan chart. The moment of inertia of the motor can normally be neglected.

**Ordering key**

**Motor, single-speed**

**APAL-a-bbbbbb-c-0**

**Motor, two-speed**

**speed ratio 1:1.5**

**ATAL-a-bbbbbb-c-0**

**speed ratio 1:2**

**ARAL-a-bbbbbb-c-0**

Number of poles<sup>1)</sup> (see motor tables): 4, 6

Rated output<sup>1)</sup> (see motor tables): The first three digits of code suffix b specify kW in integers, and the last two are decimals. Example: Code suffix 00175 denotes 1.75 kW.

Supply voltage

**Single-speed motor**

1 = 220-240 V delta/380-420 V star (sizes 63-250)<sup>2)</sup>  
220 V delta/380 V star (sizes 280-355)<sup>2)</sup>

2 = 380-420 V delta (sizes 63-250)  
380 V delta (sizes 280-355)

4 = 415 V delta (sizes 280-355)

5 = 500 V star (sizes 63-100), 500 V delta (sizes 112-355)

**Two-speed motor**

2 = 380 V 5 = 500V

1) For the higher speed of a two-speed motor.

2) Star-delta starting is not possible if the motor is star-wired.

Output kW	Motor type	Product code	Speed r/min	Efficiency		Power factor cos $\phi$ 100%	Current		Torque			
				Full load 100%	3/4 load 75%		$I_N$ A	$I_S$ A	$T_N$ Nm	$T_S$ Nm	$T_{max}$ Nm	
<b>1500 r/min = 4 poles</b>			<b>400 V 50 Hz</b>				<b>Basic design</b>					
<b>Aluminium frame</b>												
5.5	M3AA 132 S	3GAA 132 023-••C	1460	89.3	89.7	0.84	10.6	7.6	36	2.2	3.4	
5.5	<sup>1)</sup> M2AA 132 S	3GAA 132 001-••A	1450	87.0	87.0	0.83	11.1	7.3	36	2.2	3.0	
7.5	M3AA 132 M	3GAA 132 024-••C	1450	90.1	90.5	0.87	14	8.5	49	3.3	3.2	
7.5	<sup>1)</sup> M2AA 132 M	3GAA 132 002-••A	1450	88.0	88.0	0.83	14.8	7.9	49	2.5	3.2	
11	M3AA 160 M	3GAA 162 101-••C	1465	91.5	92.0	0.83	21	7.9	72	3.4	3.4	
11	<sup>1)</sup> M2AA 160 M	3GAA 162 101-••A	1460	89.1	90.2	0.81	21.5	6.0	72	2.5	3.0	
15	M3AA 160 L	3GAA 162 102-••C	1460	91.8	92.0	0.82	29	9.6	98	4.8	3.7	
15	<sup>1)</sup> M2AA 160 L	3GAA 162 102-••A	1455	91.3	92.0	0.84	28.5	7.5	98	3.3	3.3	
18.5	M3AA 180 M	3GAA 182 101-••C	1470	92.3	92.3	0.84	35	7.0	120	3.1	2.7	
22	M3AA 180 L	3GAA 182 102-••C	1470	93.1	93.6	0.85	40	8.5	143	3.6	2.9	
22	<sup>1)</sup> M2AA 180 L	3GAA 182 102-••A	1470	92.4	93.1	0.83	41	6.6	143	2.5	2.9	
30	M3AA 200 MLB	3GAA 202 001-••C	1475	93.4	93.6	0.84	55	8.2	194	4.3	3.2	
30	<sup>1)</sup> M2AA 200 MLA	3GAA 202 004-••C	1475	92.9	92.9	0.83	56	7.3	194	3.7	2.8	
37	M3AA 225 SMA	3GAA 222 001-••C	1480	93.6	93.6	0.84	68	6.6	239	2.4	2.5	
45	M3AA 225 SMB	3GAA 222 002-••C	1480	94.2	94.2	0.83	83	6.7	290	2.7	2.6	
55	M3AA 250 SMA	3GAA 252 001-••C	1480	94.6	94.6	0.86	98	7.5	355	2.3	2.8	
75	M3AA 280 SMA	3GAA 282 001-••C	1480	94.8	95.0	0.86	132	7.1	486	3.4	3.5	
90	M3AA 280 SMB	3GAA 282 002-••C	1475	95.0	95.5	0.88	157	7.7	583	5.0	3.2	
<b>Steel frame</b>												
75	M2CA 280 SA	3GCA 282 110-••A	1483	95.0	94.9	0.84	137	6.8	483	2.4	2.8	
90	M2CA 280 SMA	3GCA 282 210-••A	1484	95.2	95.1	0.85	163	7.1	579	2.7	2.9	
110	M2CA 315 SA	3GCA 312 110-••A	1487	95.4	95.1	0.85	198	6.9	706	2.1	2.8	
132	M2CA 315 SMA	3GCA 312 210-••A	1486	95.6	95.5	0.85	238	6.7	848	2.2	2.7	
160	M2CA 315 MB	3GCA 312 320-••A	1486	96.0	95.9	0.86	282	7.2	1028	2.4	2.9	
200	M2CA 315 LA	3GCA 312 510-••A	1486	96.2	96.2	0.86	351	7.2	1285	2.5	2.9	
200	M2CA 315 SA	3GCA 352 110-••A	1487	95.8	95.6	0.87	345	7.0	1284	2.1	2.7	
250	M2CA 355 MA	3GCA 352 310-••A	1487	96.5	96.4	0.87	430	7.2	1605	2.3	2.8	
315	M2CA 355 LA	3GCA 352 510-••A	1488	96.5	96.4	0.87	545	7.4	2021	2.4	2.8	
355	M2CA 355 LB	3GCA 352 520-••A	1489	96.5	96.4	0.88	605	7.2	2276	1.4	3.0	
400	<sup>2)</sup> M2CA 355 LKD	3GCA 352 540-••A	1489	96.7	96.5	0.88	680	7.5	2565	1.5	3.0	

1) Efficiency class 2.

2) Temperature rise acc. to class F.

### Recalculation factors

Recalculation factors for current at rated voltages other than 400 V 50 Hz.

Rated voltage at 50 Hz and motor wound for	Recalculation factor	Rated voltage at 50 Hz and motor wound for	Recalculation factor
220 V	1.82	500 V	0.80
230 V	1.74	660 V	0.61
415 V	0.96	690 V	0.58

Output kW	Motor type	Product code	Speed r/min	Efficiency		Power factor cos φ 100%	Current		Torque			
				Full load 100%	3/4 load 75%		I <sub>N</sub> A	I <sub>S</sub> / I <sub>N</sub>	T <sub>N</sub> N <sub>m</sub>	T <sub>S</sub> / T <sub>N</sub>	T <sub>max</sub> / T <sub>N</sub>	
<b>1000 r/min = 6 poles</b>			<b>400 V 50 Hz</b>				<b>Basic design</b>					
<b>Aluminium frame</b>												
3	M3AA 132 S	3GAA 133 001-••C	960	84.5	84.5	0.75	6.9	6.1	30	2.4	2.6	
4	M3AA 132 MA	3GAA 133 002-••C	960	85.5	85.5	0.78	8.7	7.1	40	2.6	2.8	
5.5	M3AA 132 MB	3GAA 133 003-••C	955	86.0	86.0	0.78	11.9	6.9	55	2.8	2.8	
7.5	M3AA 160 M	3GAA 163 101-••C	970	89.3	89.3	0.79	15.4	6.7	74	2.0	2.8	
11	M3AA 160 L	3GAA 163 102-••C	970	89.8	89.8	0.78	23	7.1	109	2.2	2.9	
15	M3AA 180 L	3GAA 183 101-••C	970	90.8	90.8	0.78	31	7.0	148	2.1	3.0	
18.5	M3AA 200 MLA	3GAA 203 001-••C	985	91.1	91.1	0.81	36	7.0	179	2.5	2.7	
22	M3AA 200 MLB	3GAA 203 002-••C	980	91.7	91.7	0.81	43	7.2	214	2.5	2.7	
30	M3AA 225 SMB	3GAA 223 001-••C	985	92.8	92.8	0.83	56	6.6	291	2.5	2.7	
37	M3AA 250 SMA	3GAA 253 001-••C	985	93.7	93.7	0.83	69	7.3	359	2.8	2.8	
45	M3AA 280 SMA	3GAA 283 001-••C	985	94.1	94.1	0.84	82	7.3	436	2.8	2.8	
<b>Steel frame</b>												
45	M2CA 280 SA	3GCA 283 110-••A	990	94.1	94.0	0.82	85	6.6	434	2.5	2.5	
55	M2CA 280 SMA	3GCA 283 210-••A	989	94.4	94.3	0.83	102	6.6	531	2.5	2.5	
75	M2CA 315 SA	3GCA 313 110-••A	992	94.9	94.7	0.80	143	7.1	722	2.3	2.7	
90	M2CA 315 SMA	3GCA 313 210-••A	991	95.3	95.2	0.83	165	7.1	867	2.3	2.7	
110	M2CA 315 MB	3GCA 313 320-••A	991	95.3	95.1	0.83	201	7.3	1060	2.5	2.8	
132	M2CA 315 LA	3GCA 313 510-••A	990	95.4	95.3	0.84	241	6.7	1273	2.4	2.7	
132	M2CA 355 SA	3GCA 353 110-••A	992	95.3	95.1	0.85	235	6.8	1270	1.7	2.6	
160	M2CA 355 SB	3GCA 353 120-••A	992	95.9	95.7	0.85	280	6.8	1540	1.8	2.7	
200	M2CA 355 MA	3GCA 352 310-••A	993	95.9	95.7	0.85	350	7.5	1923	2.0	2.8	
250 <sup>1)</sup>	M2CA 355 MB	3GCA 352 320-••A	991	95.9	95.8	0.80	475	7.3	2409	2.2	3.0	
315	M2CA 355 LKD	3GCA 352 540-••A	991	96.2	96.1	0.84	565	7.3	3035	2.0	3.0	

1) Temperature rise acc. to class F.

### Recalculation factors

Recalculation factors for current at rated voltages other than 400 V 50 Hz.

Rated voltage at 50 Hz and motor wound for	Recalculation factor	Rated voltage at 50 Hz and motor wound for	Recalculation factor
220 V	1.82	500 V	0.80
230 V	1.74	660 V	0.61
415 V	0.96	690 V	0.58

Output kW	Motor type	Product code	Speed r/min	Efficiency		Power factor cos $\phi$ 100%	Current		Torque			
				Full load 100%	3/4 load 75%		$I_N$ A	$I_S$ A	$T_N$ N <sub>m</sub>	$T_S$ N <sub>m</sub>	$T_{max}$ N <sub>m</sub>	
<b>750 r/min = 8 poles</b>			<b>400 V 50 Hz</b>				<b>Basic design</b>					
<b>Aluminium frame</b>												
2.2	M3AA 132 S	3GAA 134 001-••C	720	80.5	80.1	0.67	5.9	5.3	29	1.9	2.5	
3	M3AA 132 M	3GAA 134 002-••C	720	82.0	82.1	0.68	7.8	5.5	40	2.4	2.6	
4	M3AA 160 MA	3GAA 164 101-••C	715	84.1	84.7	0.69	10	5.2	54	2.1	2.4	
5.5	M3AA 160 M	3GAA 164 102-••C	710	84.7	85.5	0.70	13.4	5.4	74	2.4	2.6	
7.5	M3AA 160 L	3GAA 164 103-••C	715	86.3	87.2	0.70	18.1	5.4	100	2.4	2.8	
11	M3AA 180 L	3GAA 184 101-••C	720	88.7	89.2	0.76	23.5	5.9	146	2.4	2.6	
15	M3AA 200 MLA	3GAA 204 001-••C	740	91.1	91.1	0.82	29	7.4	194	1.8	3.0	
18.5	M3AA 225 SMA	3GAA 224 001-••C	730	91.1	91.1	0.79	37	6.2	242	1.9	2.7	
22	M3AA 225 SMB	3GAA 224 002-••C	730	91.5	91.5	0.77	45	6.0	288	1.9	2.7	
30	M3AA 250 SMA	3GAA 254 001-••C	735	92.8	92.8	0.79	59	6.9	390	1.9	2.9	
37	M3AA 280 SMA	3GAA 284 001-••C	735	93.2	93.2	0.81	71	7.2	481	2.0	2.9	
<b>Steel frame</b>												
37	M2CA 280 SA	3GCA 284 110-••A	741	93.4	93.1	0.78	74	7.3	477	1.8	3.1	
45	M2CA 280 SMA	3GCA 284 210-••A	741	94.0	93.8	0.78	90	7.6	580	1.9	3.2	
55	M2CA 315 SA	3GCA 314 110-••A	741	94.0	93.7	0.80	107	7.1	710	1.8	2.8	
75	M2CA 315 SMA	3GCA 314 210-••A	740	94.5	94.2	0.81	142	7.1	968	1.8	2.8	
90	M2CA 315 MB	3GCA 314 320-••A	740	94.7	94.5	0.82	169	7.3	1161	1.9	2.8	
110	M2CA 315 LA	3GCA 314 510-••A	740	94.8	94.7	0.83	202	7.0	1420	1.9	2.7	
110	M2CA 355 SA	3GCA 354 110-••A	742	94.6	94.0	0.80	215	5.6	1415	1.4	2.2	
132	M2CA 355 MA	3GCA 354 310-••A	743	95.0	94.5	0.77	265	5.8	1696	1.5	2.3	
160	M2CA 355 MB	3GCA 354 320-••A	742	95.2	94.8	0.79	310	6.4	2059	1.8	2.5	
200	M2CA 355 LKD	3GCA 354 540-••A	743	95.5	95.1	0.77	395	6.6	2570	1.8	2.7	

### Recalculation factors

Recalculation factors for current at rated voltages other than 400 V 50 Hz.

Rated voltage at 50 Hz and motor wound for	Recalculation factor	Rated voltage at 50 Hz and motor wound for	Recalculation factor
220 V	1.82	500 V	0.80
230 V	1.74	660 V	0.61
415 V	0.96	690 V	0.58

Output kW	Motor type	Product code	Speed r/min	Efficiency %	Power factor cos φ	Current		Torque			Moment of inertia J=1/4 GD <sup>2</sup> kgm <sup>2</sup>	Weight kg	
						I <sub>N</sub> A	I <sub>S</sub> / I <sub>N</sub>	T <sub>N</sub> Nm	T <sub>S</sub> / T <sub>N</sub>	T <sub>max</sub> / T <sub>N</sub>			
<b>1500/1000 r/min = 4/6 poles</b>			<b>400 V 50 Hz</b>			<b>Fan drive, two separate windings</b>							
<b>Aluminium frame</b>													
4.5/1.5	M3AA 132 S	3GAA 138 229--C	1460/985	83/67	0.85/0.64	9.2/5.1	6.5/4.2	29.4/14.5	1.5/1.0	2.3/2.2	0.038	48	
6/2	M3AA 132 M	3GAA 138 230--C	1460/980	84/71	0.86/0.73	12/5.6	7.1/4.5	39.2/19.5	1.8/1.3	2.5/2.0	0.048	59	
10.5/3.5	M3AA 160 M	3GAA 168 354--C	1460/965	87/75.5	0.84/0.78	21/8.6	6.4/4.1	69/35	2.0/1.3	2.5/1.7	0.089	93	
14.5/4.5	M3AA 160 L	3GAA 168 355--C	1460/970	88.5/77	0.85/0.76	28/11	6.9/4.6	95/44	2.2/1.5	2.6/1.9	0.119	117	
16/5	M3AA 180 M	3GAA 188 359--C	1470/980	89/78	0.83/0.73	31/12.5	6.3/4.6	104/49	1.9/1.5	2.5/2.0	0.176	131	
20/6.5	M3AA 180 L	3GAA 188 360--C	1470/980	90/79.5	0.83/0.74	39/16	7.2/5.0	130/63	2.4/1.8	2.7/2.0	0.224	159	
23/7.2	M3AA 200 MLA	3GAA 208 213--C	1475/985	89.5/84	0.88/0.87	43/15	7.7/7.8	149/70	1.6/1.9	2.8/2.9	0.44	175	
30/9	M3AA 200 MLB	3GAA 208 214--C	1470/990	90/86.5	0.90/0.84	54/18.2	7.7/9.5	195/87	1.6/1.7	2.7/2.9	0.53	200	
34/11	M3AA 225 SMB	3GAA 228 209--C	1470/985	91/85	0.91/0.89	60/21	7.7/6.7	221/107	1.5/1.3	2.7/2.3	0.67	225	
42/14	M3AA 225 SMC	3GAA 228 210--C	1475/985	91.5/89	0.89/0.89	75/27	8.4/6.8	272/136	1.7/1.4	3.0/2.3	0.78	255	
63/18.5	M3AA 250 SMB	3GAA 258 205--C	1475/985	93.5/87	0.89/0.79	110/40	7.5/7.3	408/179	2.4/3.0	2.7/2.6	0.89	335	
<b>Steel frame</b>													
77/25	M2CA 280 SMA	3GCA 288 214--A	1486/991	93.9/89.3	0.83/0.76	144/54	7.6/7.7	495/241	2.4/3.2	2.9/2.7	1.4	490	
90/28	M2CA 280 MB	3GCA 288 324--A	1485/991	94.2/89.8	0.86/0.78	161/58	7.4/7.7	579/270	2.3/3.2	2.7/2.8	1.7	550	
110/32	M2CA 315 SMA	3GCA 318 214--A	1489/992	95.2/91.2	0.85/0.78	199/67	6.6/6.5	706/308	1.9/2.8	2.6/2.9	2.3	730	
125/37	M2CA 315 MB	3GCA 318 324--A	1488/992	95.5/92.2	0.86/0.79	219/75	6.6/6.4	802/356	1.9/2.9	2.4/2.8	2.9	850	
150/44	M2CA 315 LA	3GCA 318 514--A	1488/991	95.7/92.6	0.87/0.79	260/88	6.6/6.4	963/424	1.9/3.0	2.4/2.7	3.5	970	
180/55	M2CA 355 MA	3GCA 358 314--A	1483/986	95.0/91.2	0.90/0.85	300/100	5.3/5.0	1159/532	1.1/1.3	2.3/2.2	6.5	1350	
260/85	M2CA 355 LA	3GCA 358 514--A	1487/988	95.7/92.0	0.90/0.85	435/155	7.7/5.9	1670/821	1.7/1.6	3.2/2.4	7.8	1550	

Output kW	Motor type	Product code	Speed r/min	Efficiency %	Power factor cos φ	Current		Torque			Moment of inertia J=1/4 GD <sup>2</sup> kgm <sup>2</sup>	Weight kg	
						I <sub>N</sub> A	I <sub>S</sub> / I <sub>N</sub>	T <sub>N</sub> Nm	T <sub>S</sub> / T <sub>N</sub>	T <sub>max</sub> / T <sub>N</sub>			
<b>1500/750 r/min = 4/8 poles</b>			<b>400 V 50 Hz</b>			<b>Fan drive, Dahlander-connection</b>							
<b>Aluminium frame</b>													
5/1	M3AA 132 S	3GAA 138 131--C	1450/725	83/74	0.87/0.59	9.9/3.3	6.4/3.6	32.9/13.2	1.5/1.0	2.3/2.0	0.038	48	
6.8/1.4	M3AA 132 M	3GAA 138 132--C	1460/730	85/73	0.84/0.55	13.7/5.1	7.6/3.6	44.5/18.3	2.0/1.4	2.8/2.7	0.048	59	
10.5/2.2	M3AA 160 M	3GAA 168 304--C	1460/735	87.5/79	0.84/0.54	21/7.4	6.9/3.7	69/29	2.2/1.5	2.7/2.3	0.089	94	
15.5/2.7	M3AA 160 L	3GAA 168 305--C	1460/735	88.5/79	0.85/0.51	30/9.5	6.9/3.9	101/35	2.2/1.7	2.6/2.6	0.119	117	
17/3.4	M3AA 180 M	3GAA 188 307--C	1470/730	88.5/78	0.85/0.56	33/11	5.8/4.3	111/44	1.7/1.2	2.3/1.9	0.176	137	
22/4.4	M3AA 180 L	3GAA 188 308--C	1475/735	89.5/79	0.83/0.53	43/15	6.7/3.9	143/57	2.0/1.7	2.6/2.3	0.224	161	
29/6.5	M3AA 200 MLA	3GAA 208 116--C	1470/730	90.5/86	0.86/0.64	54/17	6.9/4.2	188/81	2.2/1.9	2.4/1.9	0.28	180	
33/8	M3AA 200 MLB	3GAA 208 117--C	1475/730	91.5/86	0.86/0.64	61/21	7.8/4.2	214/105	2.6/1.9	2.6/1.8	0.34	205	
42/10	M3AA 225 SMB	3GAA 228 111--C	1480/740	92/89.5	0.86/0.64	85/27	7.8/5.0	271/129	2.5/2.2	3.0/2.3	0.49	265	
50/11	M3AA 225 SMC	3GAA 228 112--C	1465/735	92.5/89	0.87/0.65	91/28	7.3/4.7	324/143	2.3/2.0	2.5/2.0	0.49	265	
60/15	M3AA 250 SMB	3GAA 258 106--C	1475/735	93/90	0.86/0.70	104/34	7.9/4.7	388/195	2.6/2.1	2.7/2.0	0.89	335	
<b>Steel frame</b>													
65/15	M2CA 280 SA	3GCA 288 119--A	1484/743	93.2/90.0	0.84/0.63	121/38	7.5/5.3	418/193	2.7/2.8	2.9/2.3	1.15	445	
80/20	M2CA 280 SMA	3GCA 288 219--A	1486/743	93.8/91.5	0.83/0.63	150/50	8.5/5.4	514/257	3.3/2.9	3.4/2.6	1.4	490	
90/23	M2CA 280 MB	3GCA 288 329--A	1486/742	94.1/91.8	0.85/0.64	164/56	8.8/5.4	578/296	3.6/2.8	3.5/2.6	1.7	550	
110/32	M2CA 315 SMA	3GCA 318 219--A	1487/744	94.6/92.5	0.85/0.62	197/56	6.8/4.9	706/282	1.9/2.1	2.6/2.5	2.3	730	
132/26	M2CA 315 MB	3GCA 318 329--A	1486/746	94.9/93.0	0.86/0.64	235/65	6.8/4.8	848/334	2.0/2.0	2.6/2.4	2.9	850	
160/32	M2CA 315 LA	3GCA 318 519--A	1486/743	95.2/93.4	0.86/0.64	283/80	7.0/4.8	1028/411	2.1/2.1	2.7/2.5	3.5	970	
200/40	M2CA 355 MA	3GCA 358 319--A	1489/745	95.3/93.7	0.90/0.68	340/90	6.8/4.8	1282/512	1.4/1.3	2.8/2.5	6.5	1350	

IEC size 132

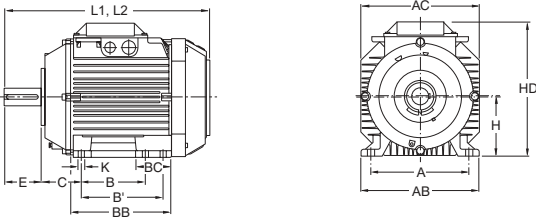

IEC sizes 160-180

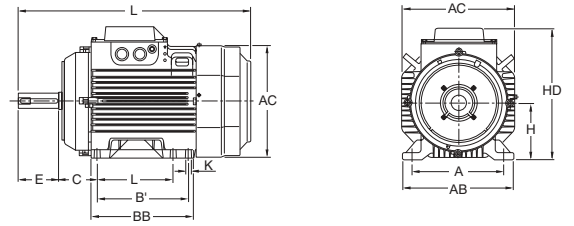

IEC sizes 200-250

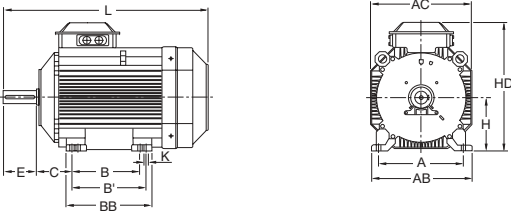

IEC sizes 280-355

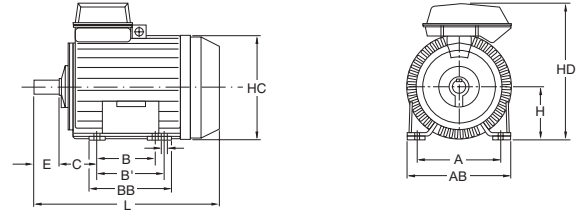

Motor shaft

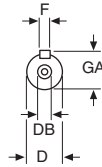

For fan arrangement 6, size 280-400 motors must have permanently connected cables (without terminal box) arranged on the opposite side as that shown in the left-hand views above.  
The cable length outside the motor should be 1.5 m.

Size as per IEC	No of poles Single-speed	No of poles Two-speed	A	AB	AC	B 1)	B' 1)	BB	C	D 1)	DB	E	EA	F 1)	GA	H 1)	HC	HD	K	L	L1 2)	L2 3)
132 S	All	All	216	262	261	140	178 4)	212	89	38	M12	80	50	10	41	132	-	295.5	12	-	447 4)	447 4) 9)
132 M	All	All	216	262	261	140 4)	178	212	89	38	M12	80	50	10	41	132	-	295.5	12	-	447 4)	481,5 4)
160 5)	5)	5)	254	310	-	210	254 4)	287.5	108	42	M16	110	-	12	45	160	-	368.5	15	602.5	-	-
160 6)	6)	6)	254	310	-	210 4)	254	287.5	108	42	M16	110	-	12	45	160	-	368.5	15	643.5	-	-
160 7)	7)	7)	279	340	-	241	279 4)	316	121	48	M16	110	-	14	51.5	180	-	403.5	15	680	-	-
180 8)	8)	8)	279	340	-	241 4)	279	316	121	48	M16	110	-	14	51.5	180	-	403.5	15	700.5	-	-
200 ML	4-8	All	318	380	386	267 4)	305	365	133	55	M20	110	-	16	59	200	-	496.5	18	773	-	-
225 SM	4-8	4/8	356	418	425	286	311 4)	360	149	60	M20	140	-	18	64	225	-	542	18	865	-	-
225 SM	4-8	4/6, 4/8	356	418	425	286 4)	311	360	149	60	M20	140	-	18	64	225	-	542	18	865	-	-
250 SM	4-8	4/6, 4/8	406	474	471	311 4)	349	409	168	65	M20	140	-	18	69	250	-	590	22	872	-	-
280 SA	4-8	4/6, 4/8	457	545	-	368	-	450	190	75	M20	140	-	20	79.5	280	558	730	24	990	-	-
280 SMA	4-8	4/6, 4/8	457	545	-	368	419	501	190	75	M20	140	-	20	79.5	280	558	730	24	1060	-	-
280 MB	4-8	4/6, 4/8	457	545	-	419	-	501	190	75	M20	140	-	20	79.5	280	558	730	24	1120	-	-
315 SA	4-8	-	508	622	624	406	-	539	216	80	M20	170	140	22	85	315	627	820	28	1125	-	-
315 SMA	4-8	4/6, 4/8	508	622	624	406	457	539	216	80	M20	170	140	22	85	315	627	820	28	1125	-	-
315 MB	4-8	4/6, 4/8	508	622	624	457	-	539	216	80	M20	170	140	22	85	315	627	820	28	1225	-	-
315 LA	4-8	4/6, 4/8	508	622	624	508	-	592	216	90	M24	170	140	25	95	315	627	820	28	1295	-	-
355 SA	4-8	-	610	714	720	500	-	584	254	100	M24	210	170	28	106	355	715	920	28	1380	-	-
355 SB	4-8	-	610	714	720	500	-	584	254	100	M24	210	170	28	106	355	715	920	28	1380	-	-
355 LA	4-8	4/6	610	714	720	630	-	714	254	100	M24	210	170	28	106	355	715	920	28	1520	-	-
355 LB	4-8	-	610	714	720	630	-	714	254	100	M24	210	170	28	106	355	715	920	28	1520	-	-
355 MA	4-8	4/6, 4/8	610	714	720	560	-	644	254	100	M24	210	170	28	106	355	715	920	28	1440	-	-
355 MB	4-8	-	610	714	720	560	-	644	254	100	M24	210	170	28	106	355	715	920	28	1440	-	-
355 LKD	4-8	-	610	714	720	630	710	802	254	100	M24	210	170	28	106	355	715	920	28	1660	-	-

- 1) Tolerances
  - A, B ISO js14
  - D = 14-28 ISO j6
  - D = 38-48 ISO k6
  - D = 55-100 ISO m6
  - F ISO h9
  - H = 132-250 +0 -0.5
  - H = 280-400 +0 -1.0
- 2) Single-speed motors and two speed motors 132 S.
- 3) Two-speed motors, high power motors excluding 132 S.
- 4) Not as per IEC
- 5) M-4, M-6, M-8, MA-8, L-4, L-6  
MA-4, M-4, L-4, M-4/6, M-4/8 and LB-4
- 6) L-8, L-4/6, L-4/8, LB-6 and LB-8
- 7) M-4, L-6, L-8, M-4, M-4/6, M-4/8
- 8) L-4, L-4/6, L-4/8, LB
- 9) For motor 132 S, increase distance L2 by 34.5 mm.

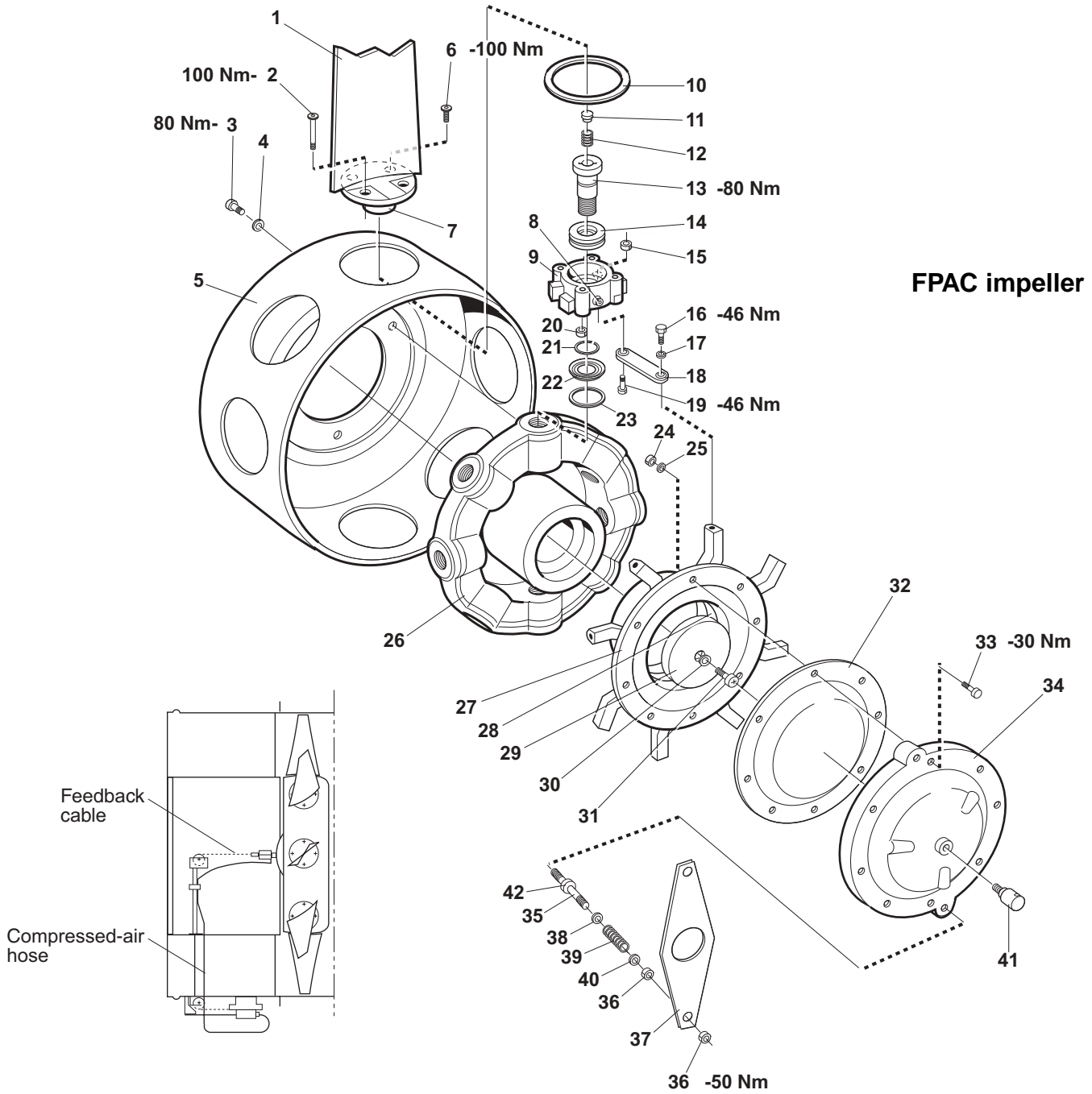

- |                    |                  |                        |
|--------------------|------------------|------------------------|
| 1. Blade           | 16. Screw        | 31. Screw              |
| 2. Screw           | 17. Washer       | 32. Diaphragm          |
| 3. Screw           | 18. Link         | 33. Screw              |
| 4. Washer          | 19. Screw        | 34. End cover          |
| 5. Shield          | 20. Nut          | 35. Driver             |
| 6. Screw           | 21. Safety ring  | 36. Nut                |
| 7. O-ring          | 22. Sealing ring | 37. Driver guide       |
| 8. Grease nipple   | 23. O-ring       | 38. Washer             |
| 9. Blade seat      | 24. Nut          | 39. Spring             |
| 10. Sealing ring   | 25. Washer       | 40. Washer             |
| 11. Peg            | 26. Hub          | 41. Rotary coupling    |
| 12. Spring         | 27. Control disc | 42. Minimum pitch stop |
| 13. Blade spindle  | 28. Slide bush   |                        |
| 14. Thrust bearing | 29. End disc     |                        |
| 15. Nut            | 30. Washer       |                        |



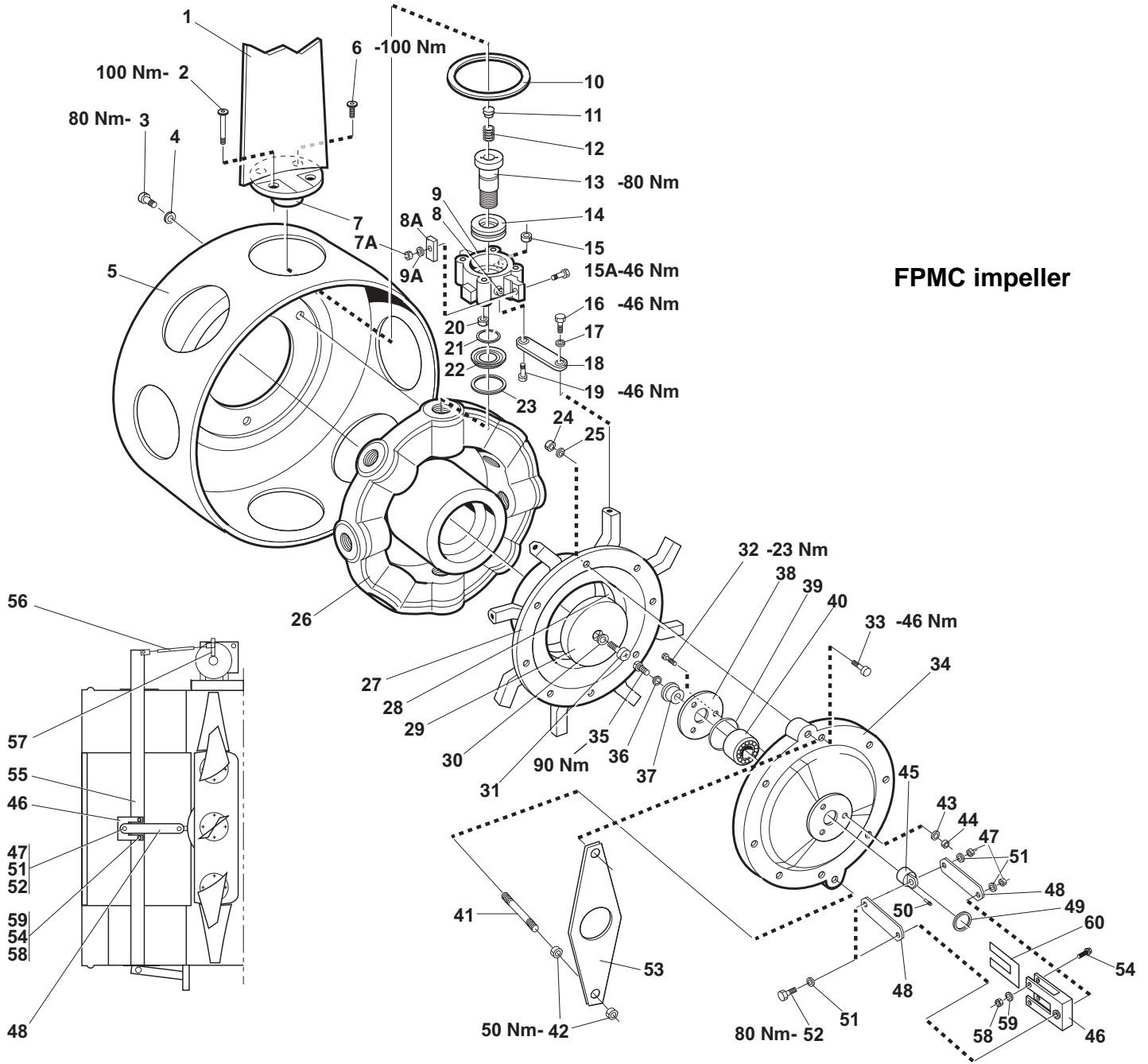

FPMC impeller

- |                    |                  |                                   |                    |
|--------------------|------------------|-----------------------------------|--------------------|
| 1. Blade           | 15a. Screw       | 33. Screw                         | 51. Washer         |
| 2. Screw           | 16. Screw        | 34. Cover                         | 52. Screw          |
| 3. Screw           | 17. Washer       | 35. Screw                         | 53. Driver guide * |
| 4. Washer          | 18. Link         | 36. Washer                        | 54. Screw          |
| 5. Fairing         | 19. Screw        | 37. Bush                          | 55. Adjustment rod |
| 6. Screw           | 20. Nut          | 38. Cover                         | 56. Turn-buckle    |
| 7. O-ring          | 21. Safety ring  | 39. O-ring                        | 57. Crank arm      |
| 7a. Nut            | 22. Sealing      | 40. Control bearing               | 58. Lock nut       |
| 8. Grease nipple   | 23. O-ring       | 41. Driver                        | 59. Washer         |
| 8a. Counter weight | 24. Nut          | 42. Nut                           | 60. Washer         |
| 9. Blade mounting  | 25. Washer       | 43. Washer                        |                    |
| 9a. Washer         | 26. Hub          | 44. Nut                           |                    |
| 10. Sealing        | 27. Control disc | 45. Link arm bracket with bushing |                    |
| 11. Peg            | 28. Slide bush   | 46. Link arm with bushing         |                    |
| 12. Spring         | 29. End disc     | 47. Nut                           |                    |
| 13. Blade spindle  | 30. Washer       | 48. Link arm                      |                    |
| 14. Thrust bearing | 31. Screw        | 49. V-ring                        |                    |
| 15. Nut            | 32. Screw        | 50. Coupling                      |                    |

\* Not fitted on certain variants